

Art. Nr. 2827596

VERSION 1

Groundplan - Grundplan - Plan de masse - Planimetria - Plattegrond
- Põhiplaan

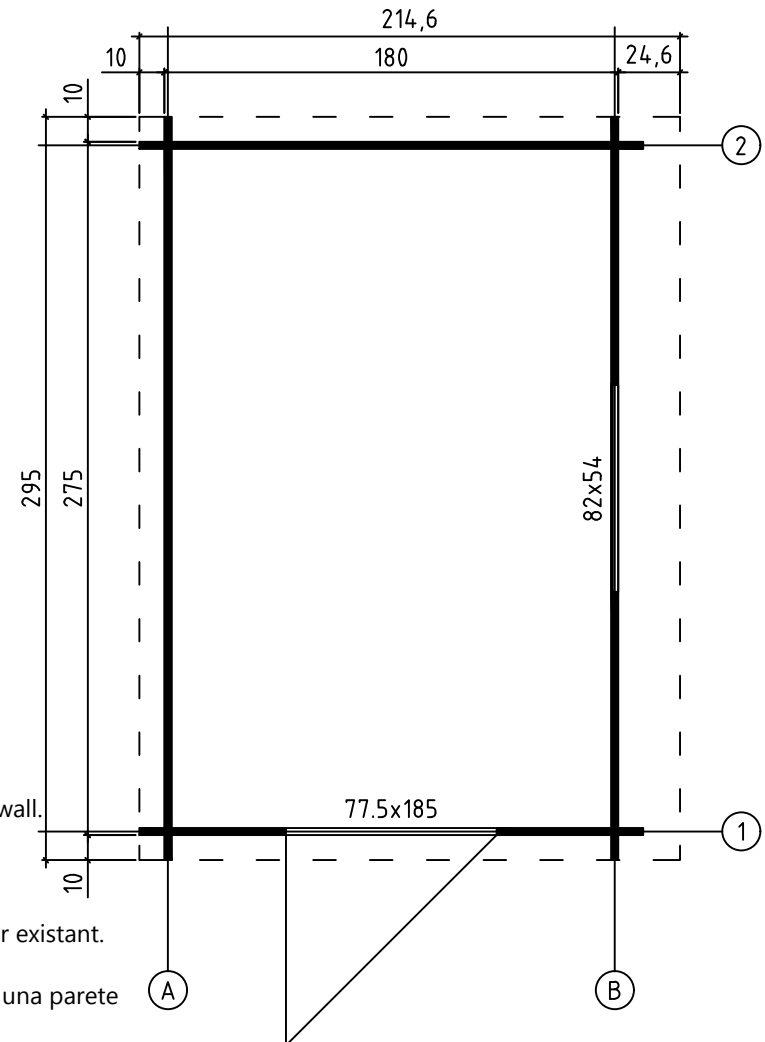
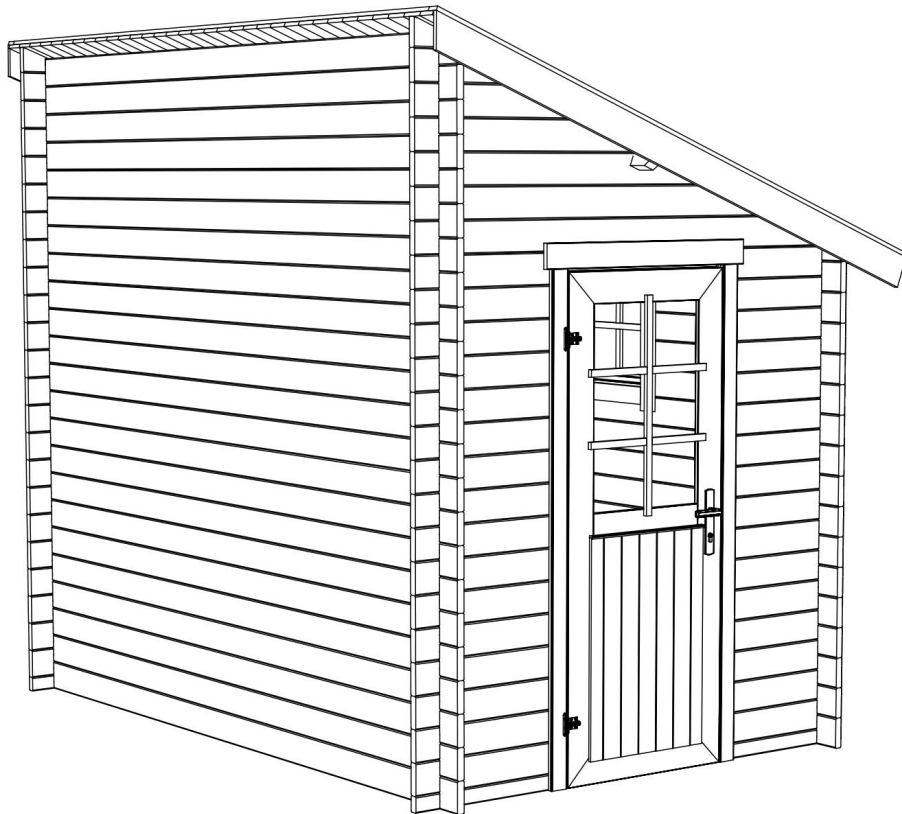

*Assembly to the existing wall.

*Anbau zu den Wand.

*Montage adossé à un mur existant.

*Montaggio addossata ad una parete esistente

*Aanbouw tegen een wand.

Art. Nr. 2827596
VERSION 1

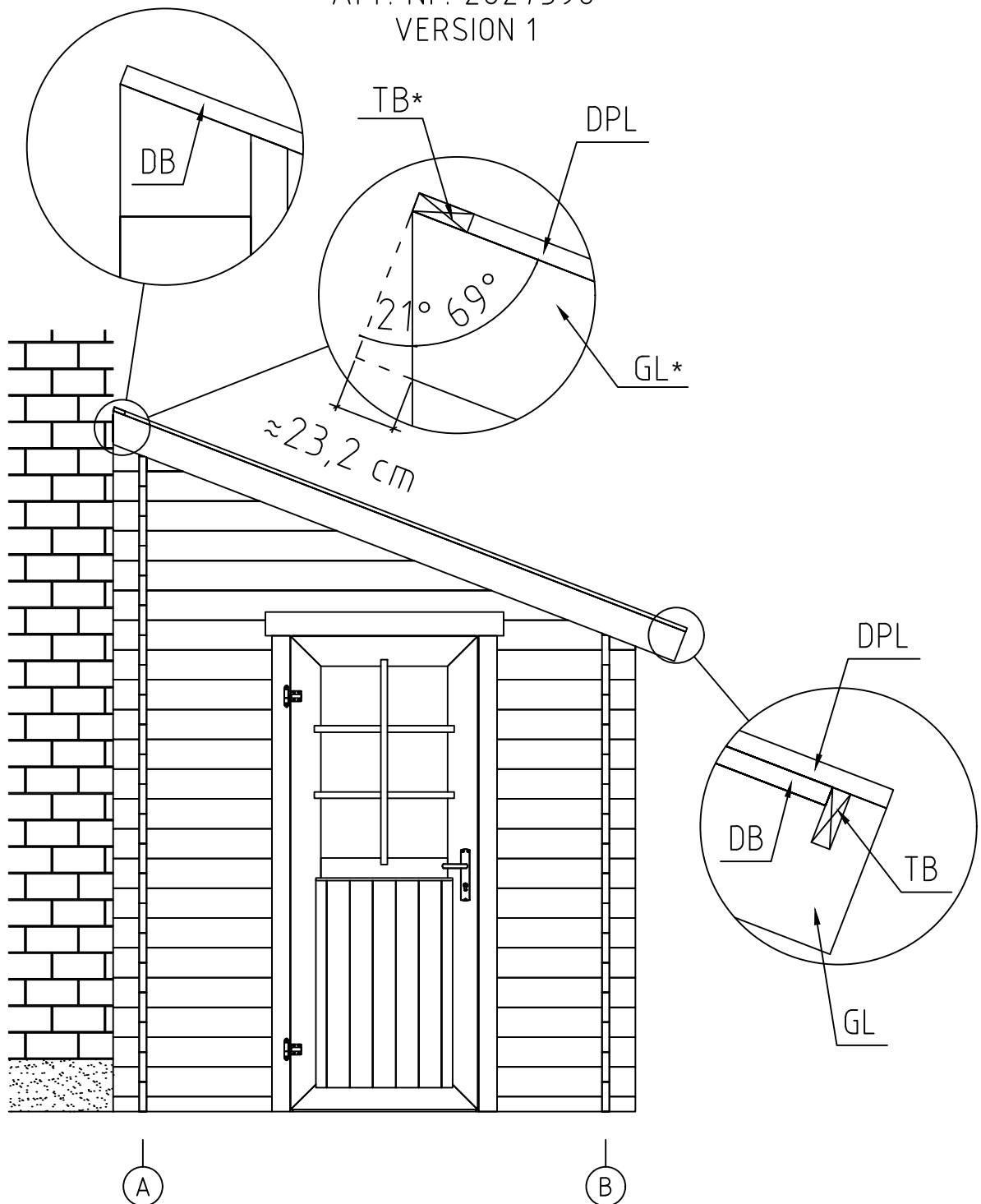

*You have to cut TB and GL to make them fit correctly.
The calculated length of TB is 289 cm.

*TB und GL passend zuschneiden. TB berechnete länge ist 289 cm.

*Instructions de découpe des détails GL et TB à suivre, pour le côté situé en haut de toiture uniquement :
- Couper l'extrémité de la planche de rive (GL) selon l'angle de coupe indiqué sur le schéma ci-dessus
- Recouper un bandeau de toit (TB) à 289 cm de longueur.

*Tagliare TB a cm 289
Tagliare n 2 GL a 69 gradi per aderire alla parete
Unire TB all'interno dei GL all'estremità dei lati tagliati a 69 gradi

*TB en GL passend afzagen. TB berekende lengte is 289 cm.

Art. Nr. 2827596

VERSION 2

Groundplan - Grundplan - Plan de masse - Planimetria - Plattegrond
- Põhiplaan

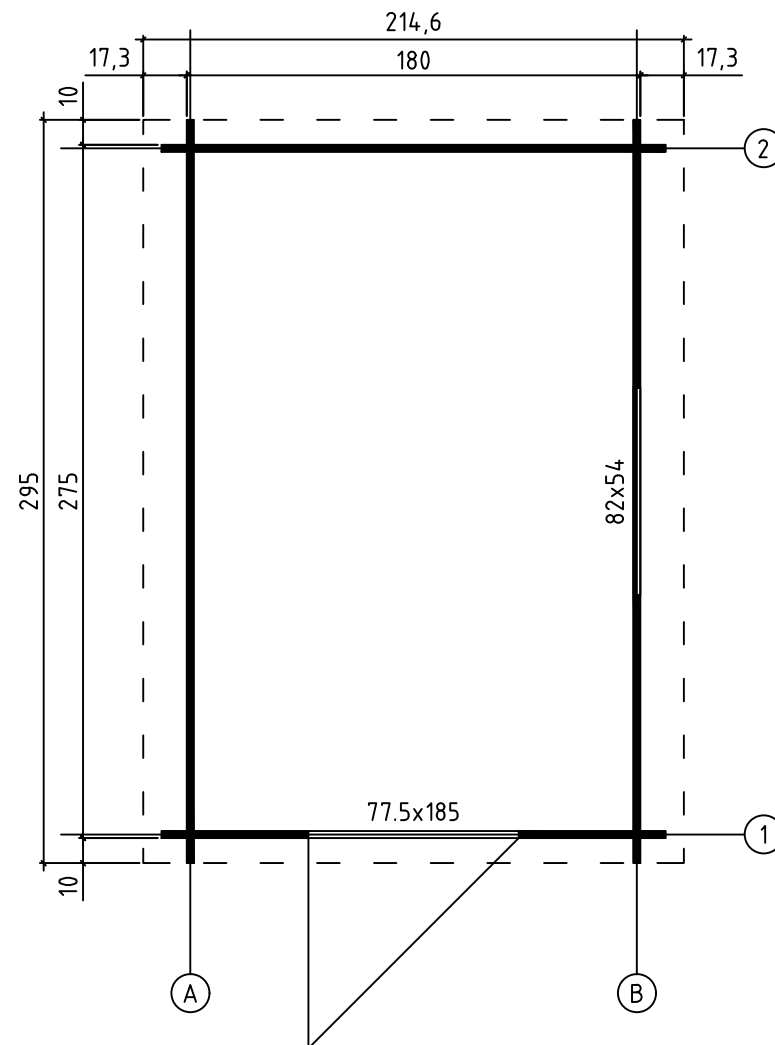
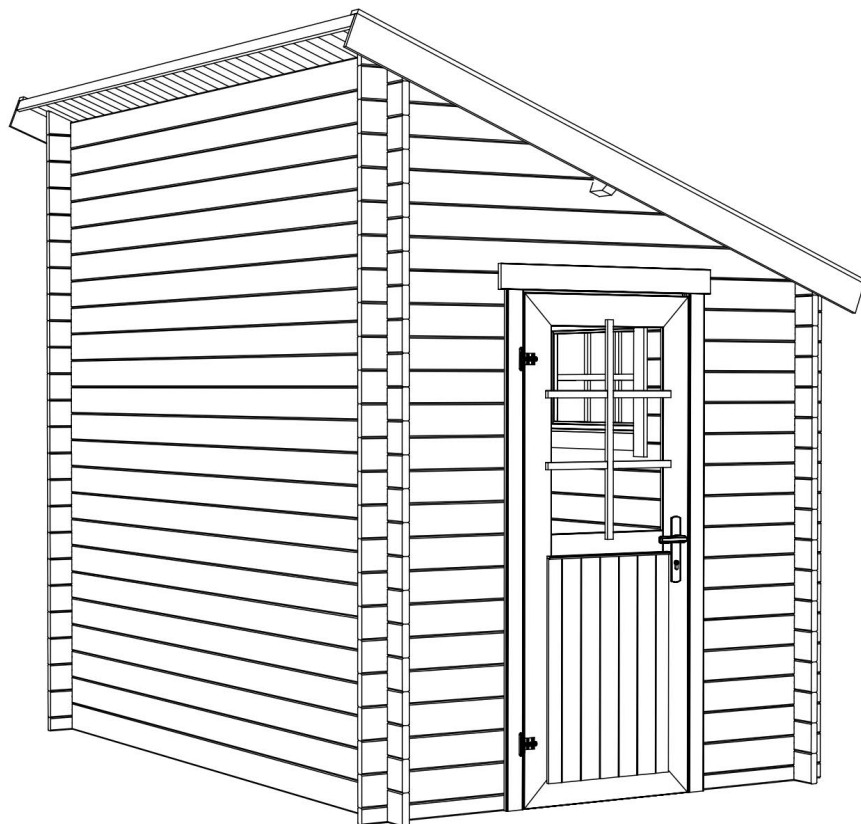

Art. Nr. 2827596

VERSION 2

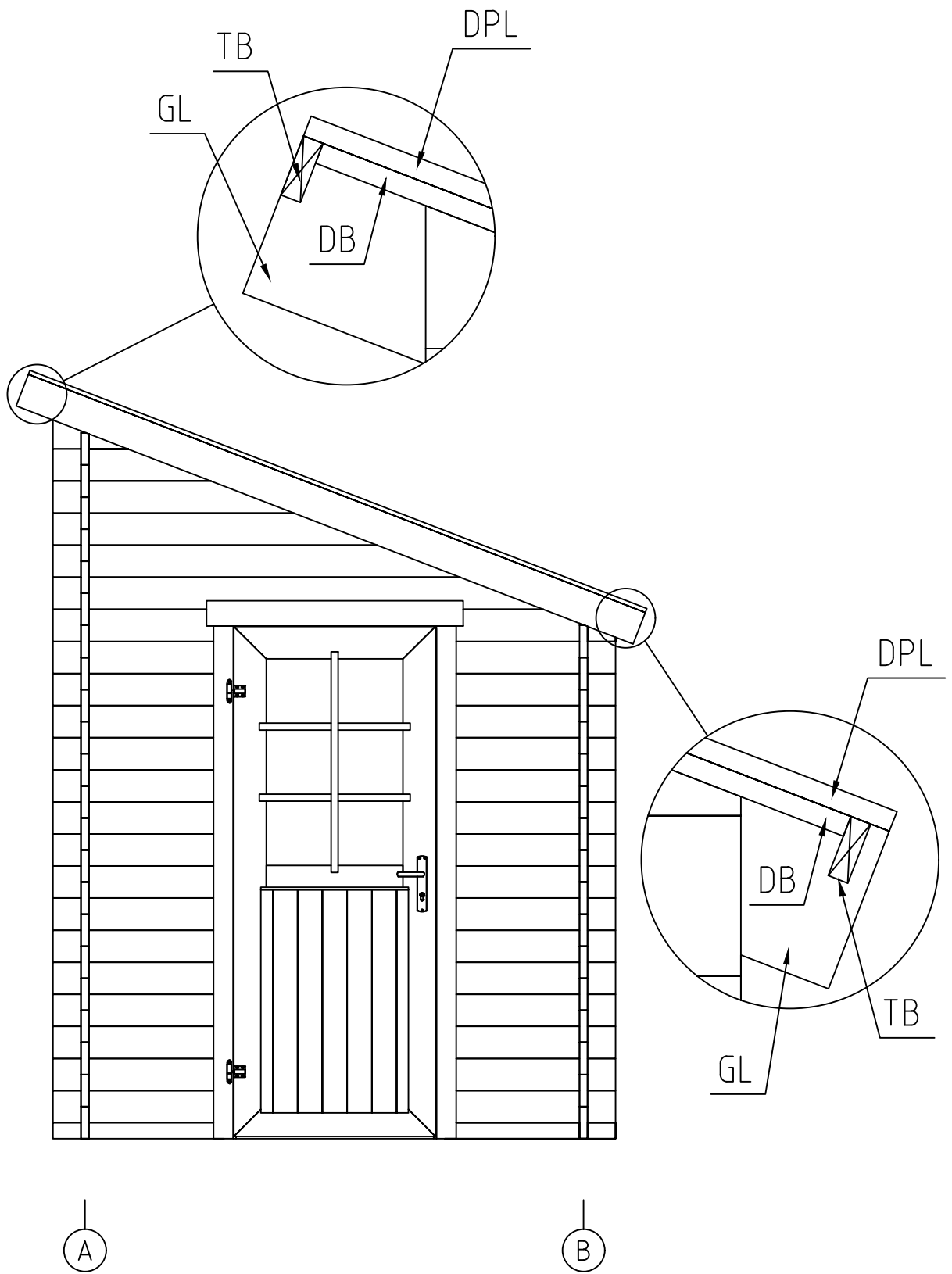

Art. Nr. 2827596

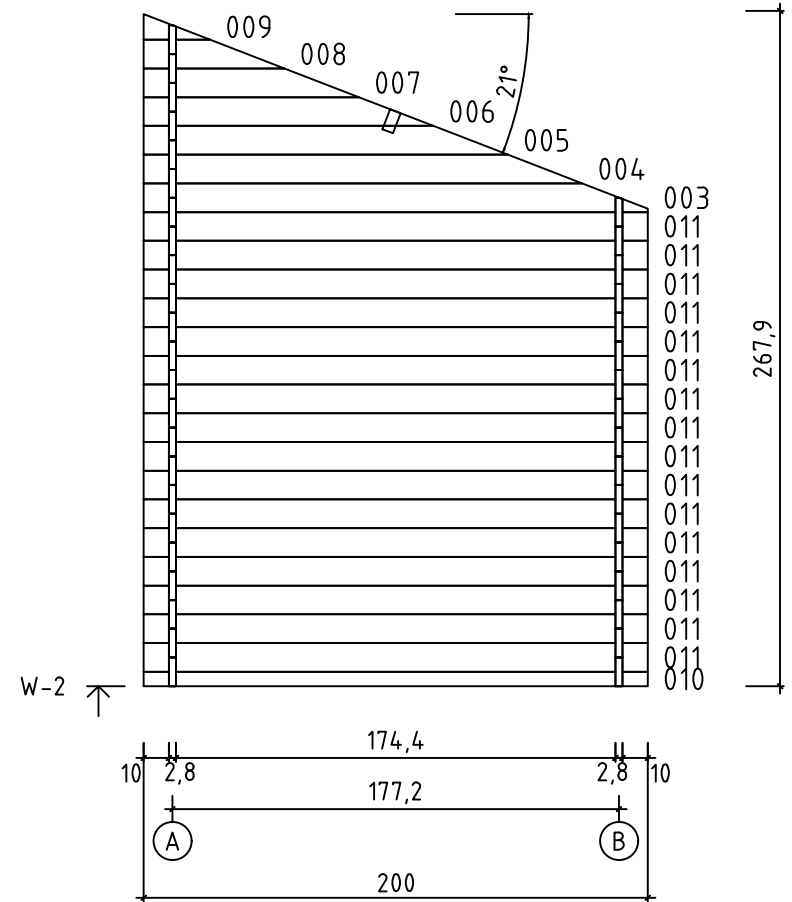
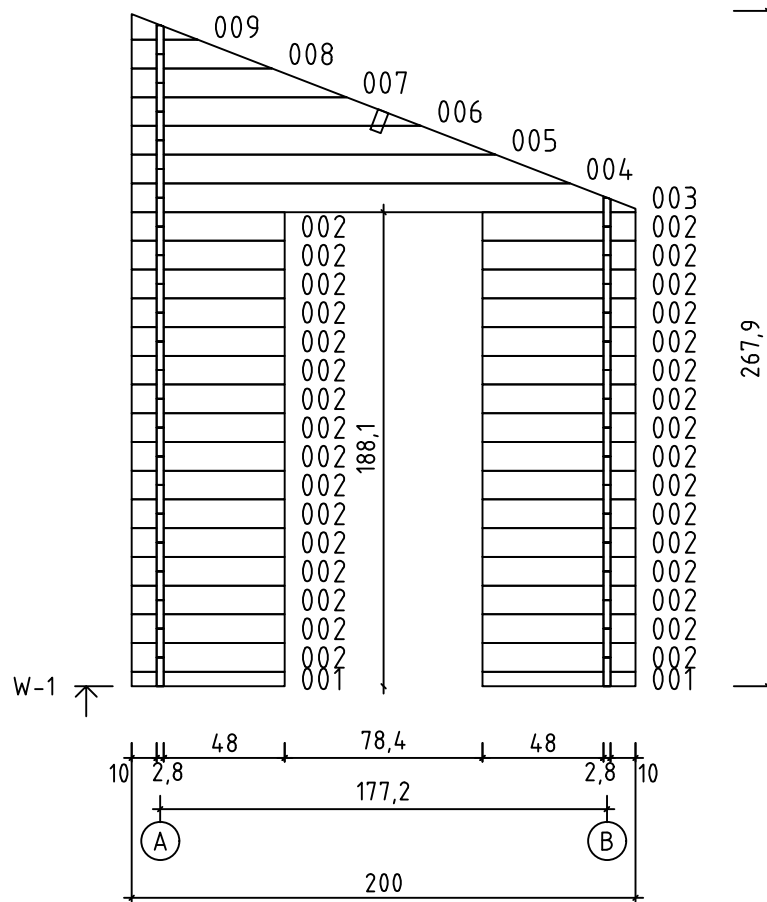





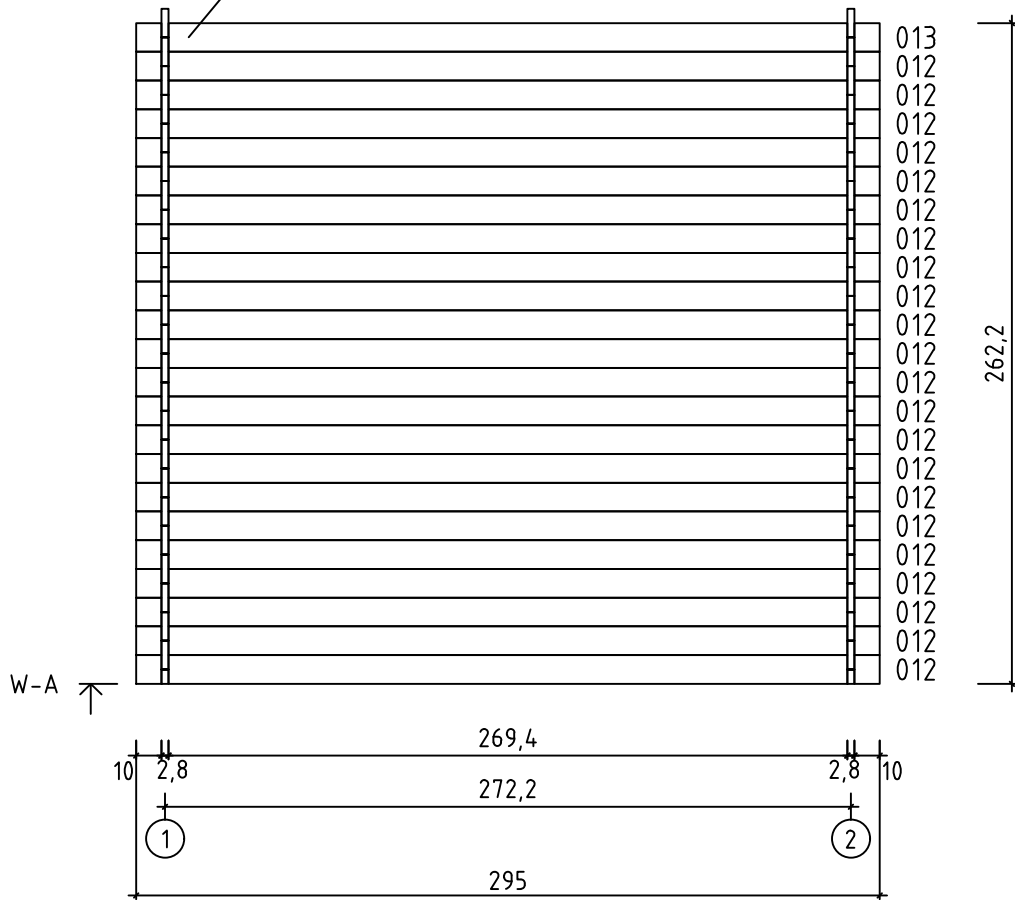

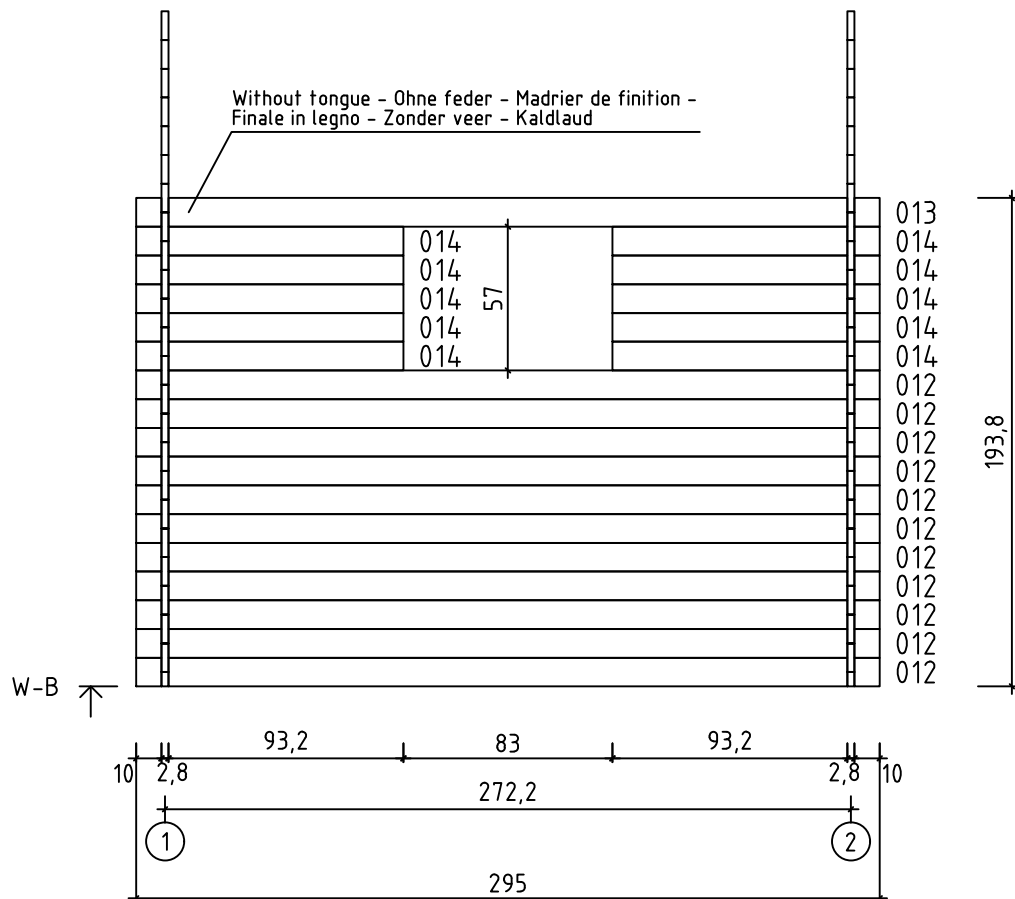

Art. Nr. 2827596

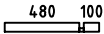
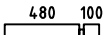
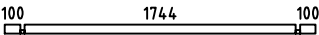
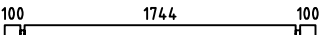
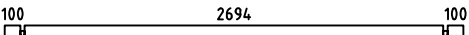
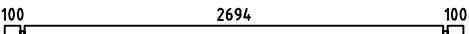
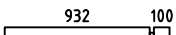
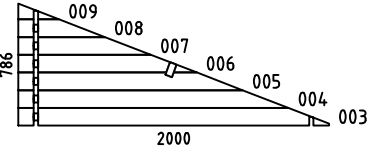
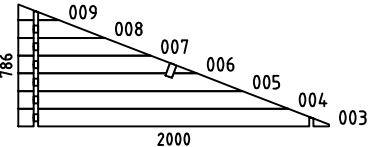
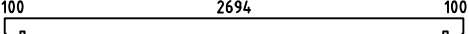



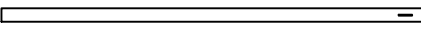
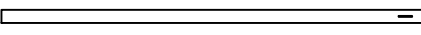

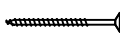
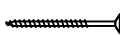
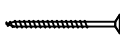
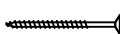

Without tongue - Ohne feder - Madrier de finition -
Finale in legno - Zonder veer - Kaldlaud

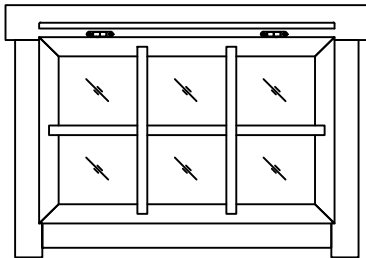
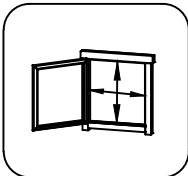
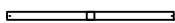
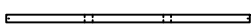

Without tongue - Ohne feder - Madrier de finition -
Finale in legno - Zonder veer - Kaldlaud

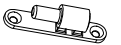
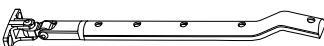

| Pos | 15.10.2019 Piece list - Stückliste - Liste des pièces - Elementi - Stuklijst - Tükitalabel Art. Nr. 2827596 | 8/9 | Q | P (mm) | L (mm) |
|-------|--|-----|----|-----------|-----------|
| 001 |  | | 2 | 28x57 | 608 |
| 002 |  | | 32 | 28x114 | 608 |
| 010 |  | | 1 | 28x57 | 2000 |
| 011 |  | | 16 | 28x114 | 2000 |
| 012 |  | | 33 | 28x114 | 2950 |
| 013 |  | | 2 | 28x120 | 2950 |
| 014 |  | | 10 | 28x114 | 1060 |
| W1-1 |  | | 1 | | |
| W2-1 |  | | 1 | | |
| A-PR1 | Roof beam - Dachbalken - Panne de toit - Perlina del tetto - Gordingen / dakbalk - Pärilin  | | 1 | 44x120 | 2950 |
| DB | Roof boards - Dachbretter - Voliges - Perlina per tetto - Dakhout - Katuselaud  | | 33 | 90x15 | 2300 |
| DPL | Roofing felt fillet - Dachpappenleiste - Baguette de fixation du feutre bitumeux - Asse per fissaggio guaina bituminosa - Afdeklijst asfaltpapier - Katusepapiilist  | | 2 | 15x45 | 2350 |
| TB | Fascia board - Traufbrett - Bandeau de toit - Finitura lati tetto - Gevellijst - Räästalaud  | | 2 | 15x45 | 2950 |
| KFS-1 | Storm protection - Sturmleiste - Latte anti-tempete - Protezione anti vento - Stormverankering / beveiliging - Tormikinnitusliist  | | 2 | 22x45 | 2050 |
| KFS-2 | Storm protection - Sturmleiste - Latte anti-tempete - Protezione anti vento - Stormverankering / beveiliging - Tormikinnitusliist  | | 2 | 22x45 | 2500 |
| GL | Gable moulding - Giebelleiste - Planche de rive - Finitura per frontale e retro del tetto - Gevellijst - Viilulaud  | | 2 | 15x120 | 2350 |
| HS9 | Screw for gable moulding - Schrauben für giebelleiste - Vis pour fixation planche de rive - Vite per fissare finiture davanti e dietro del tetto - Schroef voor gevellijst - Kruvi viilulauale  | | 12 | 3.5x50 | |
| HS12 | Screw for fascia boards - Schrauben für traufbretter - Vis pour fixation bandeau de toit - Viti x striscia del tetto - Schroef voor gevellijst - Kruvi räästalauale  | | 14 | 4x40 | |
| HS18 | Screw for roof beams - Schrauben für dachbalken - Vis pour fixation pannes de toit - Viti per perline del tetto - Schroef voor gordingen / dakbalken - Kruvi pärlinitele  | | 6 | 5x120 | |
| HS18 | Screw for gable - Schrauben für giebel - Vis pour fixation des pignons - Viti per timpano - Schroef voor gevelpunt - Kruvi viilude kinnitamiseks  | | 28 | 5x120 | |
| SH28 | Hammer block - Schlagholz - Calle de frappe - Blocco di legno da usare come cuscinetto quando si usa il martello - Slagklos - Löögiklots  | | 1 | | |

| Pos | 19.01.2018 | Piece list - Stückliste - Liste des pièces - Elementi - Stuklijst - Tükítabel 820x540 AK.1.106.SVA.h SGA | 1/1 | Q | P (mm) | L (mm) |
|------|---|---|---|---|-----------|------------|
| | | Glass size - Glasgröße - Taille de la vitre - Misura del vetro - Glas afmeting - Klaasi mõõt: 676x396 mm |  | | | |
| | | |  | | | 720x440 mm |
| 1 | Georgian bars - Sprossen - Croisillons - La griglia georgiana - Raamverdeling - Petteliistud |  | | 2 | 15x25 | 430 |
| 2 | Georgian bars - Sprossen - Croisillons - La griglia georgiana - Raamverdeling - Petteliistud |  | | 1 | 15x25 | 710 |
| 3 | Batten - Deckleiste - Profils de finition angles a l'exterieur - Asse Afdek lijst - Katteliist |  | | 1 | 15x25 | 760 |
| HS1 | Screw for georgian bars - Schraube für sprossen - Vis pour croisillons - Viti per unire la griglia georgiana della finestra - Schroeven voor raamverdeling - Kruvi akna petteliistule |  | | 6 | 2.5x20 | |
| HS10 | Screw for window hinge - Schraube für fenster scharnier - Vis pour Fenetre charniere - Viti per cerniera a finestra - Schroef voor raam scharnier - Kruvi akna polthingele |  | | 4 | 4x25 | |
| HS10 | Screw for window fixator - Fensterfixierung - Fenžtre fixator - Vite per fissatore di finestra - Schroef voor raambevestiger - Kruvi akna fiksaatorile |  | | 6 | 4x25 | |
| NF2 | Zn nail - Zn nägel - Pointe - Chiodi - Nagel - Nael |  | | 5 | 1.4x40 | |
| NA1 | Hinge for window - Scharnier für fenster - Charniere pour fenetre - Cerniere per Finestra - Raam scharnier - Aknahing |  | | 2 | | |
| NA2 | Hinge for window - Scharnier für fenster - Charniere pour fenetre - Cerniere per Finestra - Raam scharnier - Aknahing |  | | 2 | | |
| NA3 | Window fixator - Fensterfixierung - Fenžtre fixator - Fissatore della finesra - Raam(ver)dichting - Akna fiksaator |  | | 1 | | |
| NA4 | Window fixator - Fensterfixierung - Fenžtre fixator - Fissatore della finesra - Raam(ver)dichting - Akna fiksaator |  | | 1 | | |
| NA5 | Window fixator - Fensterfixierung - Fenžtre fixator - Fissatore della finesra - Raam(ver)dichting - Akna fiksaator |  | | 1 | | |

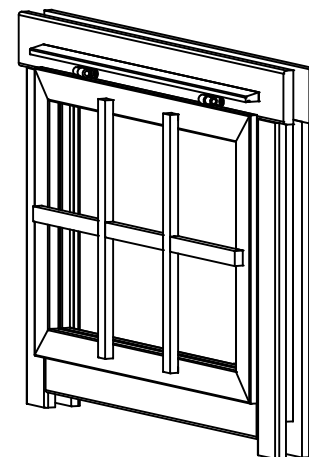
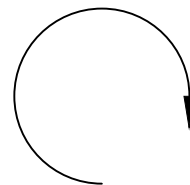
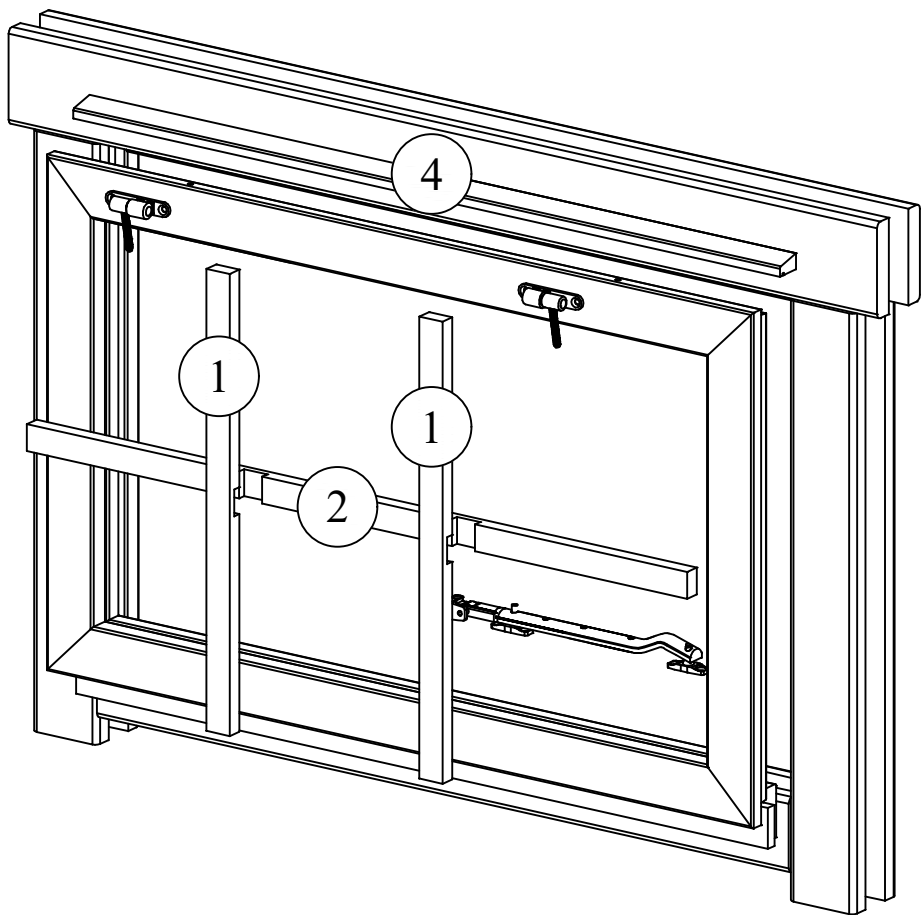

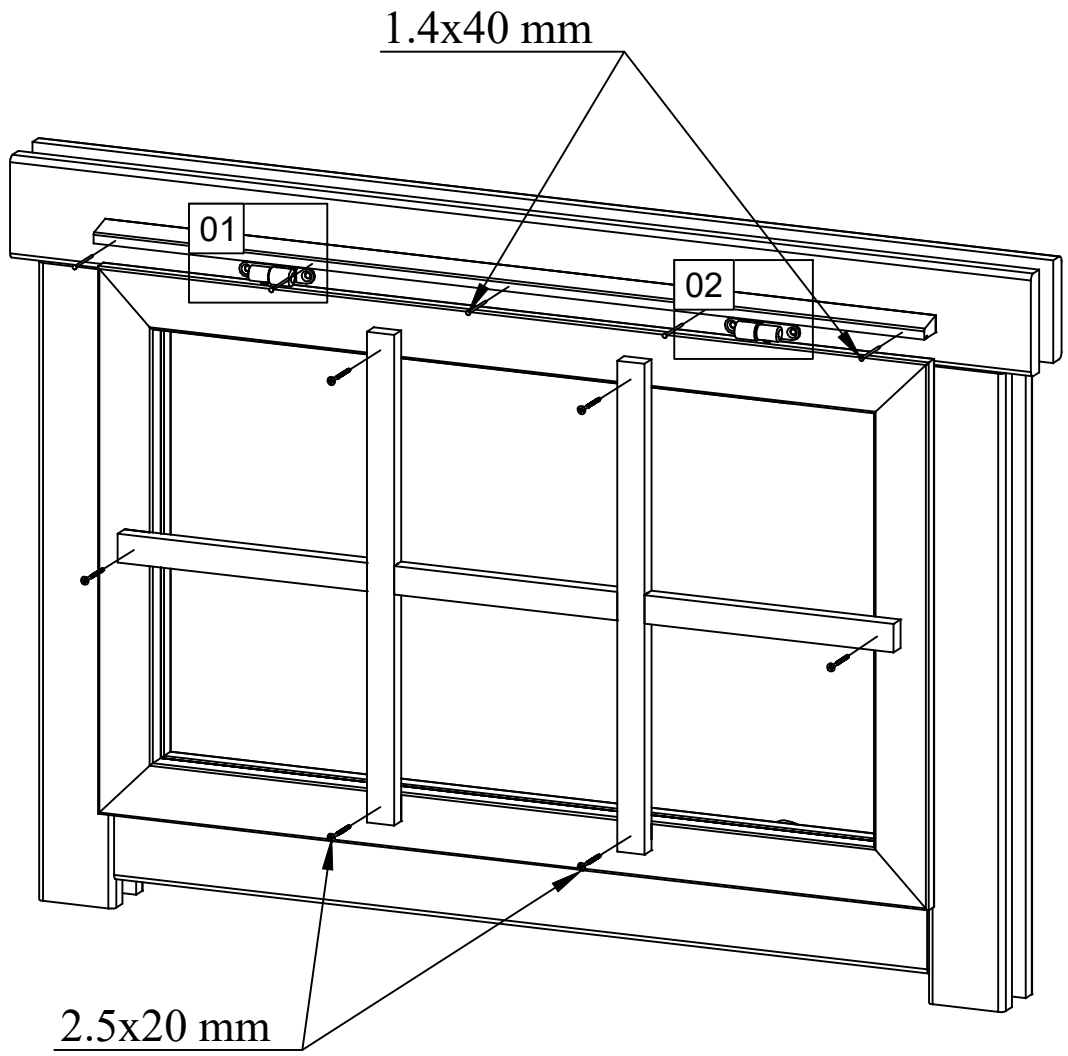

01a/02a

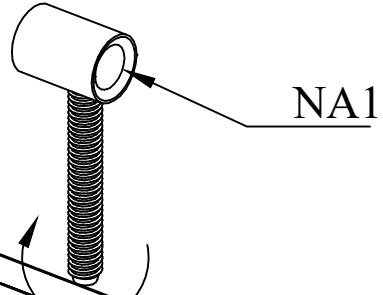

01b

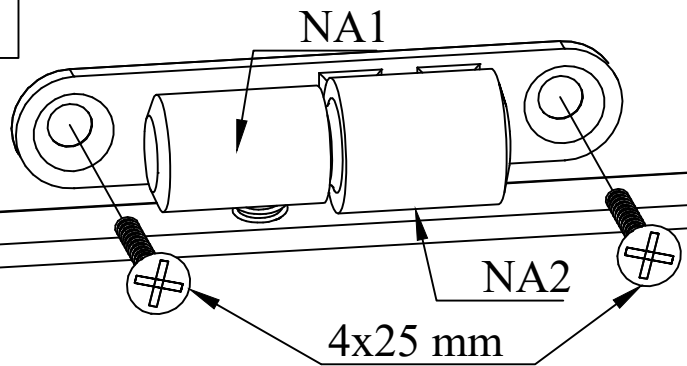

02b

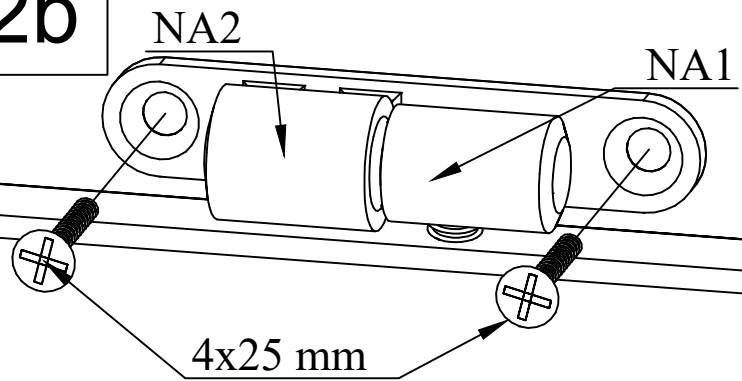

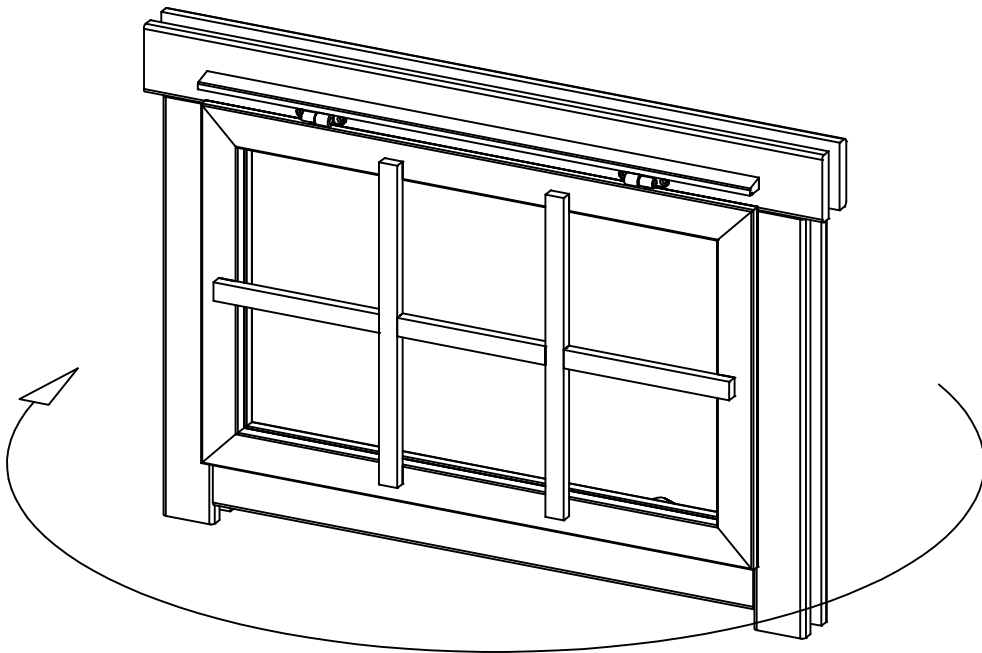

03

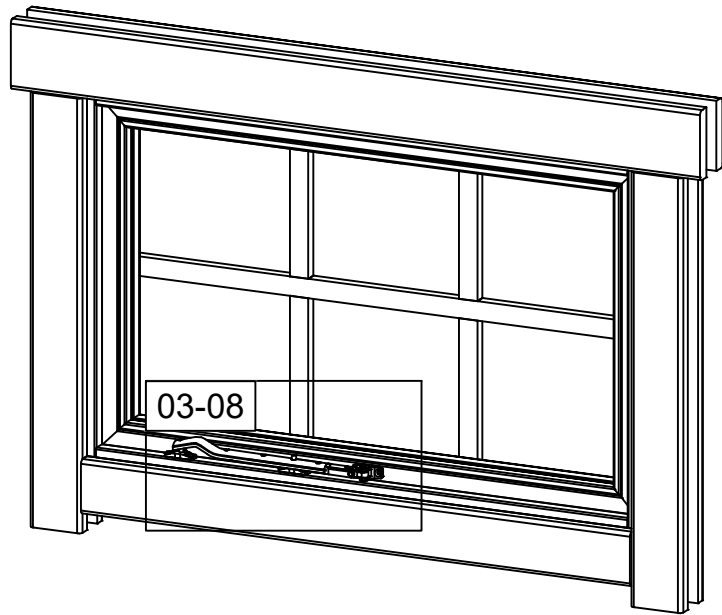
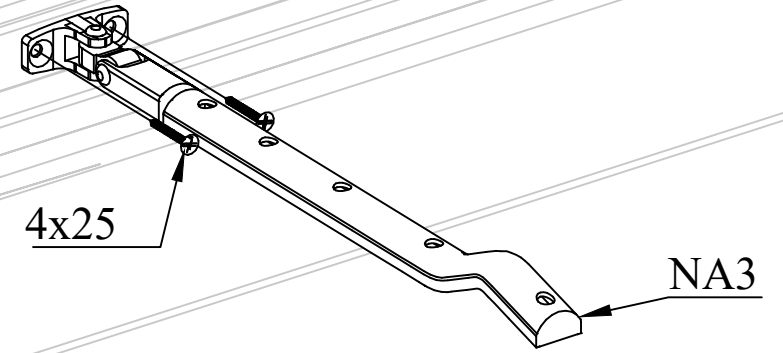

04

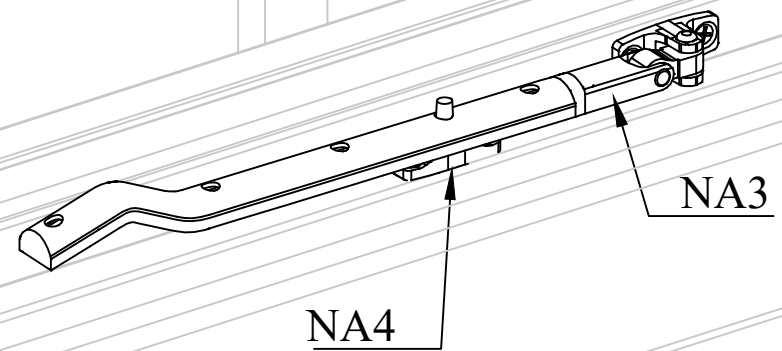

05

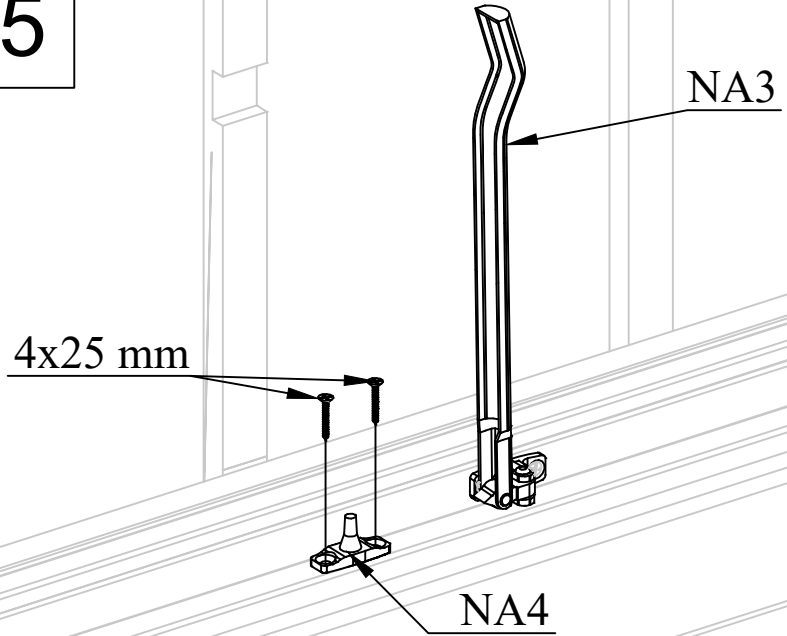

07

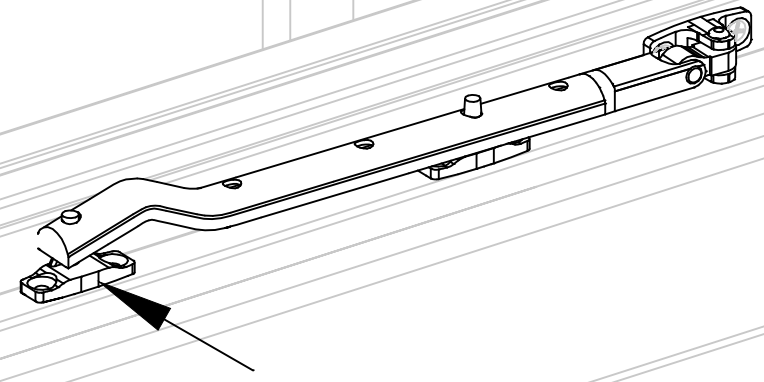



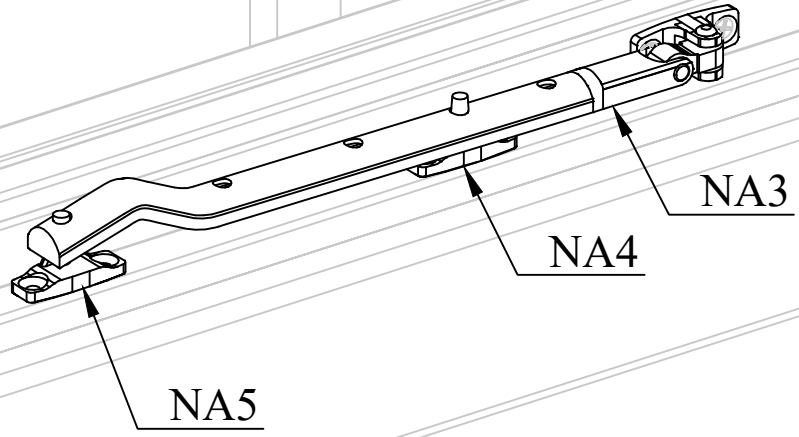

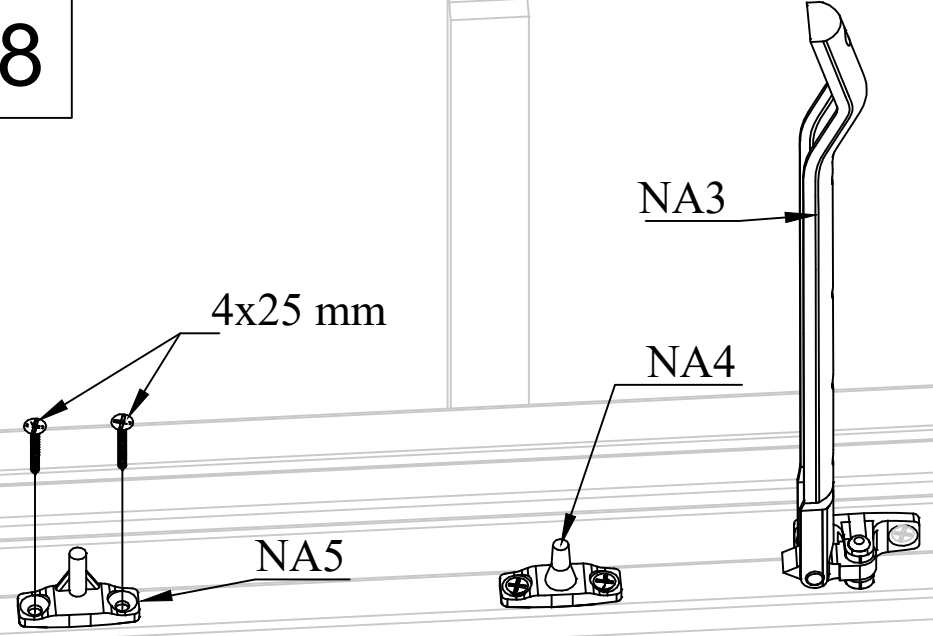

06

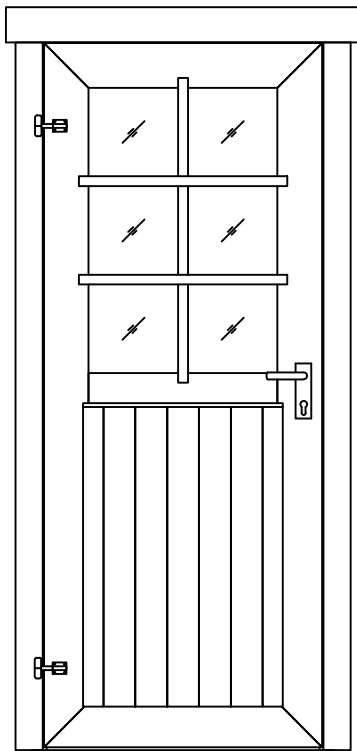
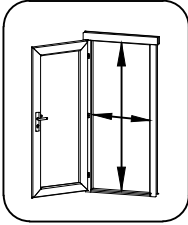

08



| Pos | 19.12.2017 | Piece list - Stückliste - Liste des pièces - Elementi - Stuklijst - Tükítabel 775x1850 UK.2.056.SVV.MX28 SGA+28 | 1/2 | Q | P (mm) | L (mm) |
|-----|--|--|-----|--------|-----------|-----------|
| | | Glass size - Glasgröße - Taille de la vitre - Misura del vetro - Glas afmeting - Klaasi mõõt: 502x750 mm | | | | |
| | |  | | | | |
| | |  702x1794 mm | | | | |
| 1 | Upper door jamb - Türrahmen oben - Cadre de porte supérieur - Telaio superiore della porta - Bovendorpel - Ukse ülemine leng |  | 1 | 66x100 | 722 | |
| 2 | Left door jamb - Türrahmen links - Cadre de porte gauche - Telaio montante sinistro della porta - Linkerstijl deurframe - Ukse vasak leng |  | 1 | 66x80 | 1850 | |
| 3 | Right door jamb - Türrahmen rechts - Cadre de porte droit - Telaio montante destro della porta - Rechterstijl deurframe - Ukse parem leng |  | 1 | 66x80 | 1850 | |
| 4 | Doorstep - Swelle - Barre de seuil - Soglia della porta - Deurdorpel - Lävepak |  | 1 | 18x18 | 702 | |
| 5 | Georgian bars - Sprossen - Croisillons - La griglia georgiana - Raamverdeling - Petteliistud |  | 1 | 15x25 | 784 | |
| 6 | Georgian bars - Sprossen - Croisillons - La griglia georgiana - Raamverdeling - Petteliistud |  | 2 | 15x25 | 536 | |

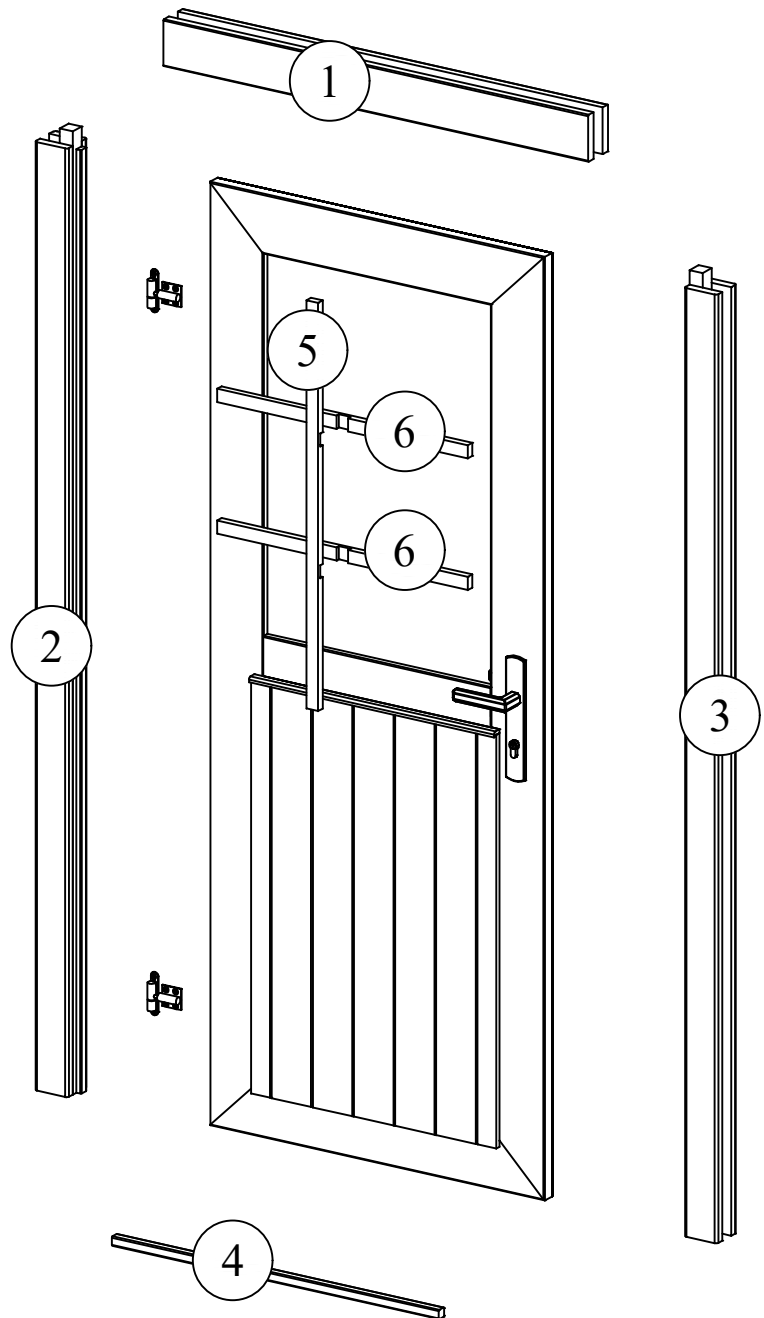

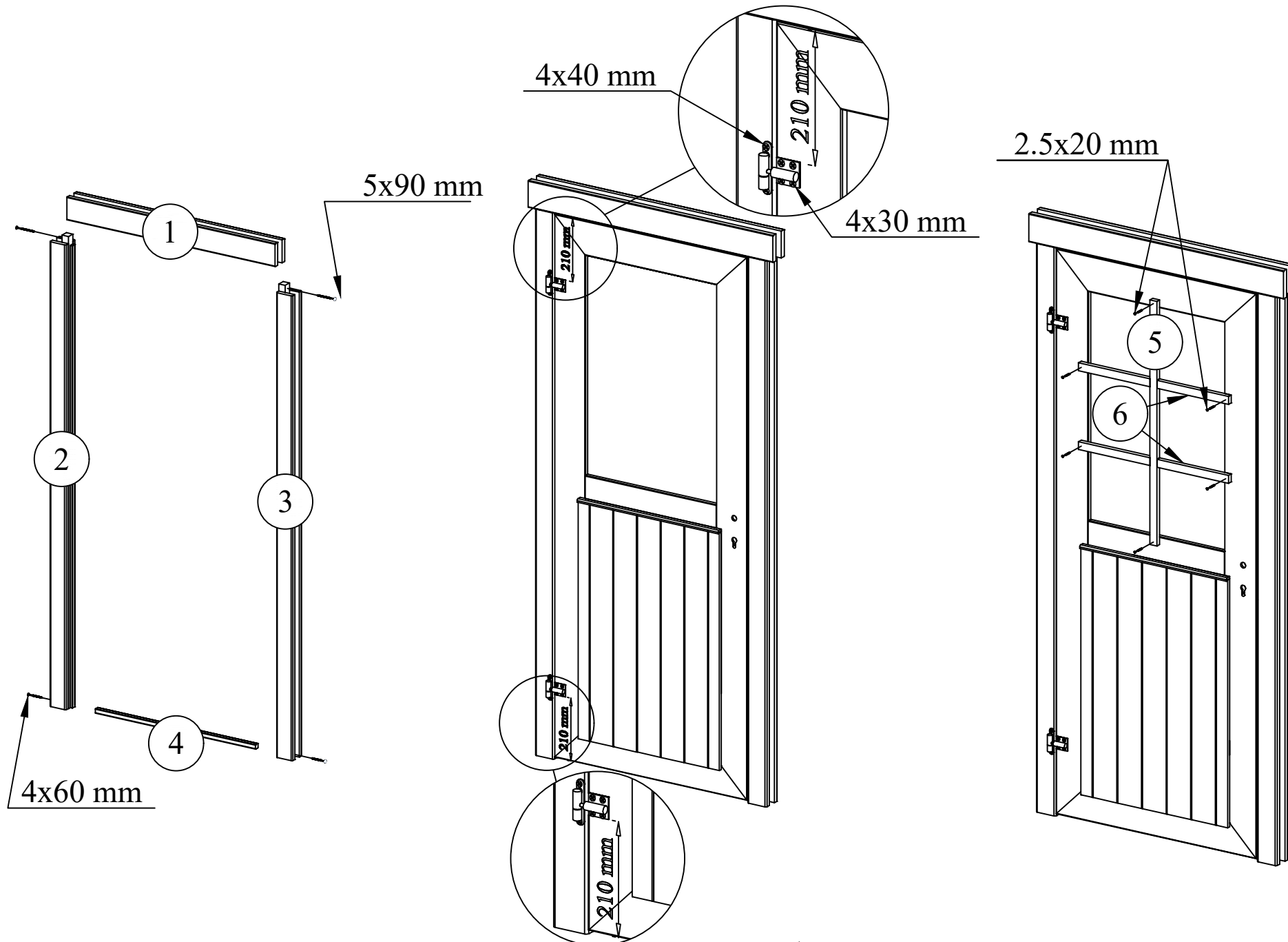

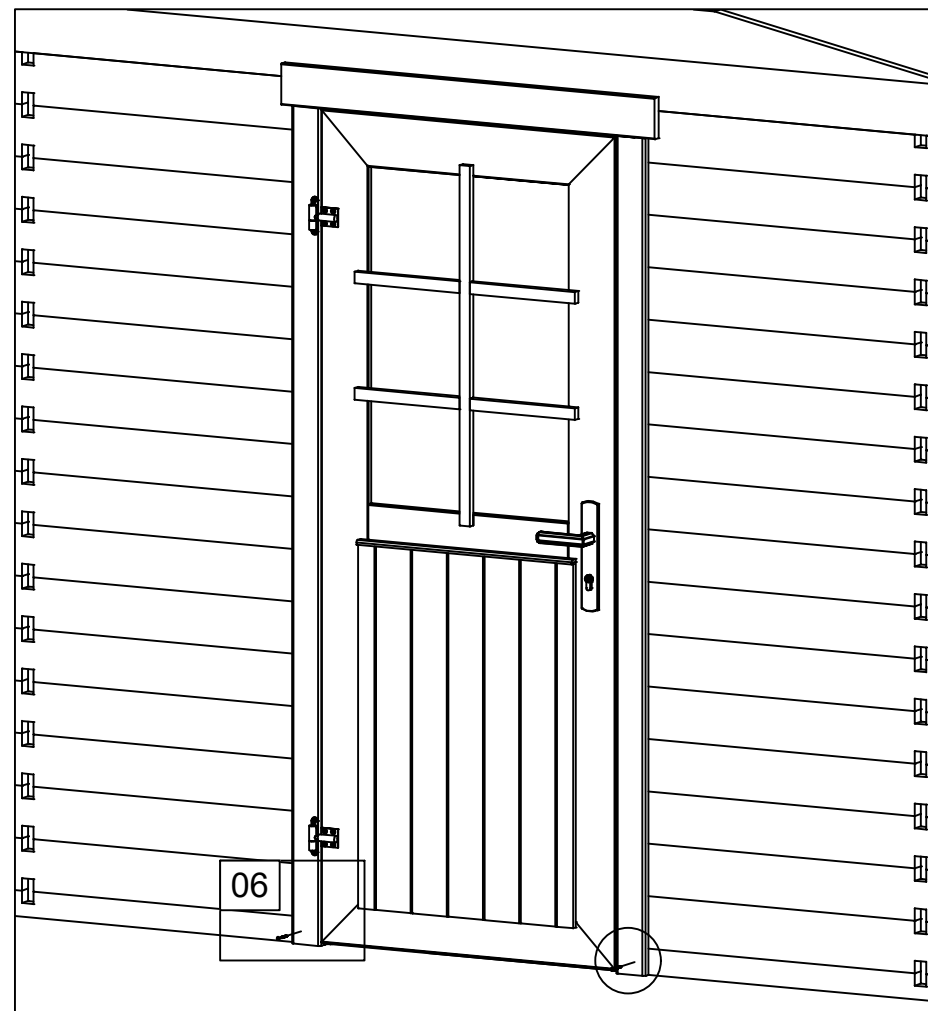

01

4x25 mm

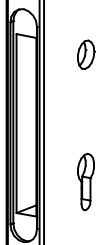
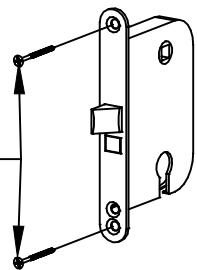

04

4x25 mm

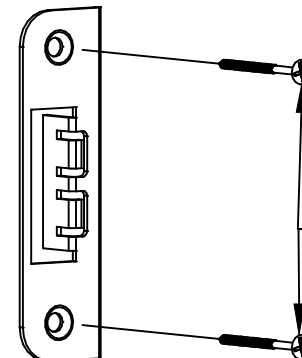

02

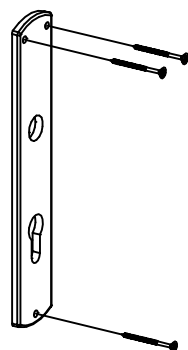
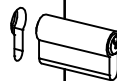
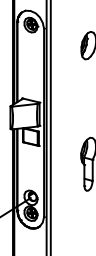
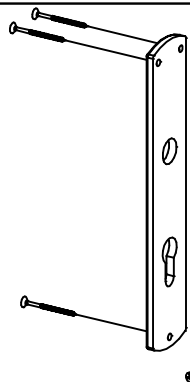

05

3x30 mm

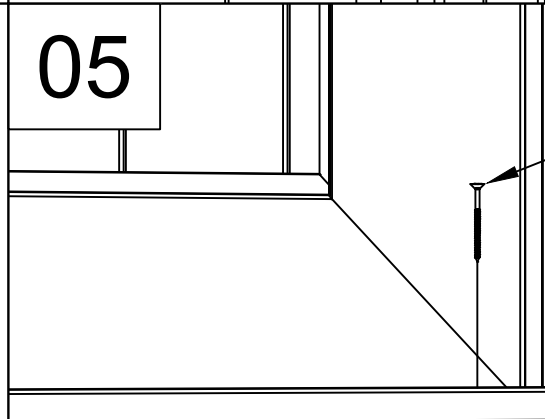

03

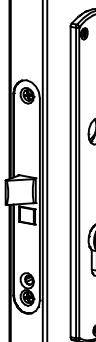
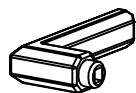

06

3.5x50 mm

