

# 1 Üldinfo



## Lugupeetud klient,

Meil on hea meel, et olete otsustanud meie aiamaja kasuks!

**Palume Teil enne maja paigaldamisega alustamist montaažjuhend väga hoolikalt läbi lugeda!** Nii väldite probleeme ja asjatut ajakulu.

### Nõuanded:

- Säilitage majapakki kuni lõpliku kokkumonteerimiseni kuivas kohas, vältides otsesest kokkupuudet maapinnaga ning kaitstuna ilmastikutingimuste (niiskus, päike jms) eest. Ärge hoidke majapakki kuumaks köetud ruumis!
- Aiamaja asukoha valikul jälgige, et maja ei jääks ekstreemsete ilmastikuolude meelevalda (tugeva lumesaju või tuulega piirkonnad), vastasel korral peaksite maja kinnitama (nt ankrute abil) aluspinnase külge.



## Garantii

Teie maja on valmistatud kõrge kvaliteetsest kuusepuidust ja tarnitakse naturaalsel (töötlemata) kujul. Kui hoolimata meie põhjalikust kontrollist peaks kaebusi esinema, esitage kauba müüjale täidetud kontroll-leht ja ostuarve.

**TÄHELEPANU: Palume kindlasti säilitada maja juurde kuuluv dokumentatsioon! Kontroll-lehelt leiate maja kontrollnumbri. Kaebustega saab arvestada ainult juhul, kui Te edastate müüjale maja kontrollnumbri!**

### Garantii alla ei kuulu:

- Puidu kui looduslikust materjali loomulikust käitumisest ja iseärasustest tulenevad muutused – paisumine, kahanemine ning toonierinevused
- Detailid, mis on juba värvitud (puidukaitsevahendiga töödeldud)
- Detailid, milles esineb terveid/sissekasvanud oksid, mis ei kahjusta maja stabiilsust
- Puidu struktuuri erinevustest tingitud erinevad värvitoonid, mis ei mõjuta puidu eluiga
- Detailid, milles on (kuivamisest tingitud) väikesed praod/lõhed, mis ei ole läbivad ning ei mõjuta maja konstruktsiooni stabiilsust
- Väändunud puitdetailid
- Katuse- ja põrandalauad, mille mitterahuldavatel pindadel võib esineda hõõveldamata pinda, värvierinevusi ja poomkantsust
- Kaebused, mille on põhjustanud maja asjatundmatu paigaldus või maja vajumine asjatundmatult valmistatud vundamendi tõttu
- Kaebused, mis on põhjustatud omaalgatuslikest muudatustest maja juures, nagu nt puitdetailide ja uste/akende kõveraks tõmbumine asjatundmatu puidu töötlemise tõttu; tormiliistude liiga jäik kinnitamine, ukseraamide krüvimine seinadetailide külge jms.

**Garantii alla kuuluvate kaebuste rahuldamine piirdub puuduva/vigase materjali väljavahetamisega. Kõik muud nõudmised on välistatud! Tootja jätab endale õiguse toote tehnilisteks muudatusteks.**



## Aiamaja värvimine ja hooldus

Puit on looduslik materjal ning kasvab ja kahaneb sõltuvalt ilmastikuoludest. Suured ja väikesed praod, värvitoonide erinevused ning muutused, samuti muutuv puidustruktuur ei ole vead, vaid on puu kasvamise tulemus ning puidu kui loodusliku materjali omapära.

Töötlemata puit (va vundamendiprussid) muutub seistes mõne aja pärast hallikaks, võib tõmbuda siniseks ja minna hallitama. Et kaitsta oma aiamaja puitdetailide, peate Te need koheselt puidukaitsevahendiga töötlemata.

Soovitame katta põrandalauad eelnevalt värvitu puiduimmutusvahendiga, eriti laudade alumised küljed, millele pärast maja kokkumonteerimist enam ligi ei pääse. Ainult sel juhul saab takistada niiskuse sisseimbumist.

Soovitame kindlasti töödelda puiduimmutusvahendiga ka uksi ja aknaid. Oluline on uksi-aknaid töödelda kindlasti nii seest- kui ka väljastpoolt! Vastasel korral võivad nad kõveraks tõmbuda.

Pärast maja montaaži soovitame lõplikul viimistlusel kasutada ilmastikuolude kaitseks värvi, mis kaitseb puitu niiskuse ja UV-kiirguse eest.

Värvimisel kasutage kõrgekvaliteedilisi tööriistu ja värve, järgige värvide kasutusjuhendit, tootja ohutus- ja kasutamisharjutusi. Ärge kunagi värvige otsese päikese käes ega vihmase ilmaga. Laske end erialaspetsialistil nõustada töötlemata okaspuu jaoks mõeldud värvide osas ja järgige värvitootja juhiseid.

Reeglipärane maja värvimine pikendab oluliselt Teie aiamaja eluiga. Kord poole aasta järel soovitame Teil maja hoolikalt üle vaadata.

## 2 Ettevalmistus montaažiks

### Töövahendid ja detailide ettevalmistus

Aiamaja montaažiks on Teil vaja järgmisi tööriistu:



montaažiabiline



redel



haamer



vesilood



kruvikeeraja



saag



nuga



mõõdulint











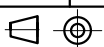

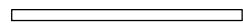
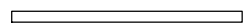
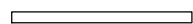

tangid

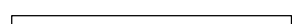







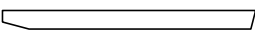

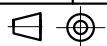



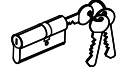

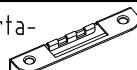
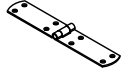
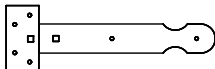





puur

**NÕUANNE:** Vältimaks võimalikke pinde, soovitame kanda monteerimise ajal vastavaid kaitsekindaid.

Pos	SPECIFICATION-STÜCKLISTE-NOMENCLATURE-ELEMENTI-ESPECIFICACIÓN EL16-2719	Pcs	Profile (mm)	Length (mm)
Wel-1	Wall element- Wandelement- Panneau du mur- Elemento di muro- Elemento pared	6	48x900	1843
Wel-2	Wall element- Wandelement- Panneau du mur- Elemento di muro- Elemento pared	1	48x900	1843
Wel-3	Wall element- Wandelement- Panneau du mur- Elemento di muro- Elemento pared	2	48x1350	951
Wel-4	Wall element- Wandelement- Panneau du mur- Elemento di muro- Elemento pared	3	48x100	899
Wel-5	Wall element- Wandelement- Panneau du mur- Elemento di muro- Elemento pared	2	48x1316	441
Wel-6	Wall element- Wandelement- Panneau du mur- Elemento di muro- Elemento pared	2	48x1316	441
DEL1-1	Door element- Türelement- Panneau du porte- Elemento di porta- Elemento puerta	1	48x800	1735
Wel-7	Wall element- Wandelement- Panneau du mur- Elemento di muro- Elemento pared	2	48x1190	354
Wel-8	Wall element- Wandelement- Panneau du mur- Elemento di muro- Elemento pared	2	48x1190	515
Rel1-1	Roof element- Dachelement- Panneau de toit- Elemento di tetto- Elemento tejado	6	56x881	1610
			Object name EL16-2719	
			Page 1/3	

Pos	SPECIFICATION-STÜCKLISTE-NOMENCLATURE-ELEMENTI-ESPECIFICACIÓN EL 16-2719	Pcs	Profile (mm)	Length (mm)
BM1	 Beam- Balken- Poutre- Trave- Viga	2	45x70	1483
BM3	 Beam- Balken- Poutre- Trave- Viga	1	45x70	1483
BM2	 Beam- Balken- Poutre- Trave- Viga	2	45x70	1160
BM4	 Beam- Balken- Poutre- Trave- Viga	1	45x70	1160
CnB3	 Connecting board- Verbindungsbrett- Madrier de connection- Tavola di collegamento- Listón de juntura	1	120x28	2160
CnB4	 Connecting board- Verbindungsbrett- Madrier de connection- Tavola di collegamento- Listón de juntura	1	95x19	1690
CnB2	 Connecting board- Verbindungsbrett- Madrier de connection- Tavola di collegamento- Listón de juntura	2	45x32	340
CnB1	 Connecting board- Verbindungsbrett- Madrier de connection- Tavola di collegamento- Listón de juntura	2	28x64	1800
CoB3	 Covering board- Deckbrett- Madrier de couverture- Tavola di copertura- Listón de cubierta	2	70x19	1050
CoB4	 Covering board- Deckbrett- Madrier de couverture- Tavola di copertura- Listón de cubierta	1	45x16	2160
CoB2	 Covering board- Deckbrett- Madrier de couverture- Tavola di copertura- Listón de cubierta	8	45x16	1870
CoB5	 Covering board- Deckbrett- Madrier de couverture- Tavola di copertura- Listón de cubierta	2	45x16	1050
CoB1	 Covering board- Deckbrett- Madrier de couverture- Tavola di copertura- Listón de cubierta	1	45x16	410
SP1	 Support brace- Stützleiste- Baguette de support- Listello di supporto- Listón de soporte	2	70x45	650
Dia-1	Diamond- Deckbrett- Madrier- Tavola di copertura- Rombo 	2	19x140	300
FaB3-1	Facia board- Giebelblende- Écran frontal- Schermo frontone- Tabla de facia 	4	16x120	1630

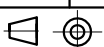

Pos	SPECIFICATION-STÜCKLISTE-NOMENCLATURE-ELEMENTI-ESPECIFICACIÓN EL16-2719	Pcs	Profile (mm)	Length (mm)
Fim	-Fixing kit- Befestigungsset- Moyens de fixation- Materiale di fissaggio- Kit de fijación		1	
QPOYP6x 60Zn	Bolt -Schloss-schraube -Boulon- Bullone- Perno- M6x60mm		12	
QULSI30x 40	Cylinder- Zylinderschloss- Serrure a mortaiser- Serratura a cilindro- Bombin- 30.40		1	
QLIU KAPal	Door fittings- Türbeschlag- Ferrure- Ferramenta porta- Manilla puerta- QLIUKAPal		1	
QLVU-6	Door fittings- Türbeschlag- Ferrure- Ferramenta porta- Manilla puerta- Vasturaud 0068 Zn mantel		1	
QLH30x2 00kZn	Door hinge- Türbänder- Charniere de porte- Cerniere porta- Bisagra de puerta- QLH30x200kZn		6	
QHT200k Zn	Door hinge- Türbänder- Charniere de porte- Cerniere porta- Bisagra de puerta- QHT200kZn		6	
QTA35x1 00kZn	Hasp- Haspe- Porte-cadenas- Portaluchetto- Amella para candado- 100x35x2.5kZn		8	
QR30100k Zn-1	Hook- Haken- Crochet- Ganzio- Pestillo QR30100kZn-1		4	
QNU40x4 0x40Zn	L-iron- Winkel- Angle -Angolo- Angulo 40x40x40		2	
QMUKK6 Zn	Nut- Schraubenmutter- Écrou- Dado- Tuerca- M6mm		12	
QKRPP3 _5x25Zn	Screw- Schraube- Vis- Vite- Tornillo- 3.5x25mm Zn		2	
QKRPP3 _5x40Zn	Screw- Schraube- Vis- Vite- Tornillo- 3.5x40mm		80	
QKRPP3x 16kZn	Screw- Schraube- Vis- Vite- Tornillo- 3x16mm kZn		32	
QKRPP3x 30Zn	Screw- Schraube- Vis- Vite- Tornillo- 3x30mm		10	
QKRPP4 _5x50Zn	Screw- Schraube- Vis- Vite- Tornillo- 4.5x50mm		26	
QKRPP4 _5x60Zn	Screw- Schraube- Vis- Vite- Tornillo- 4.5x60mm		24	
QKRPP4 _5x70Zn	Screw- Schraube- Vis- Vite- Tornillo- 4.5x70mm		110	
QKRPP4x 25kZn	Screw- Schraube- Vis- Vite- Tornillo- 4x25mm kZn		132	
QKRPP5x 90Zn	Screw- Schraube- Vis- Vite- Tornillo- 5x90mm		18	
QKRPP6x 120Zn	Screw- Schraube- Vis- Vite- Tornillo- 6x120mm		46	
QKS4x40	Snap hook- Karabiner- Mousqueton- Moschettone- Mosquetón KH40 4x40		4	
QSE6x18 Zn	Washer- Dichtscheibe- Joint- Rondella- Arandela- 6x18mm		12	
	Object name EL16-2719		Page 3/3	

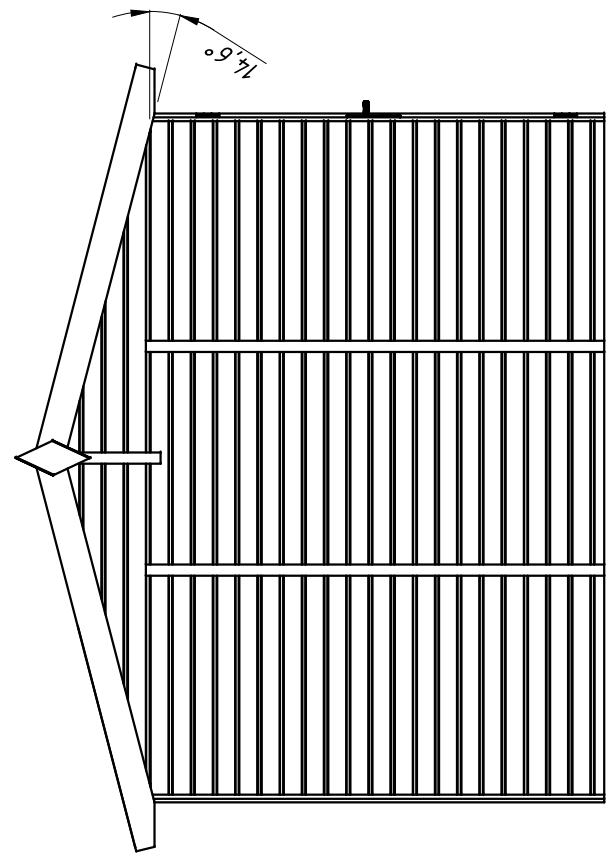
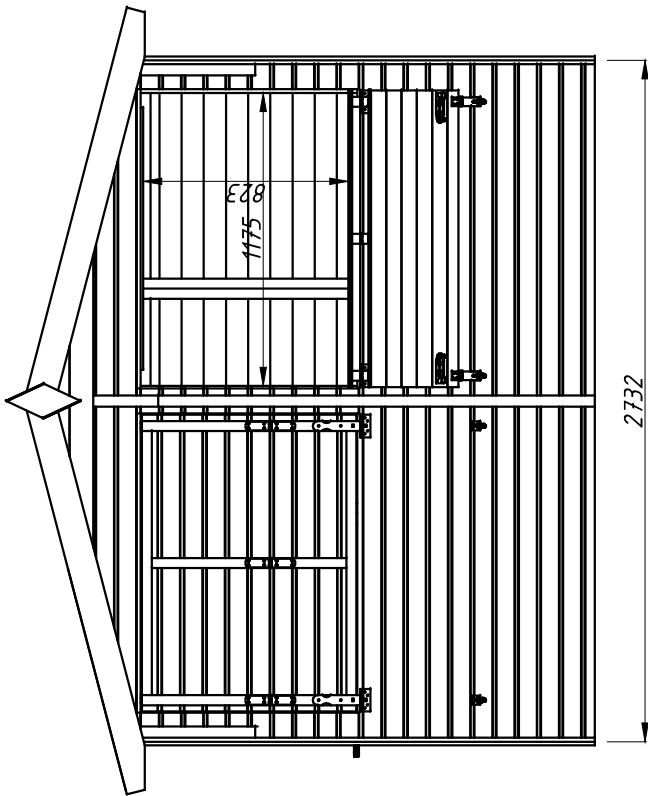
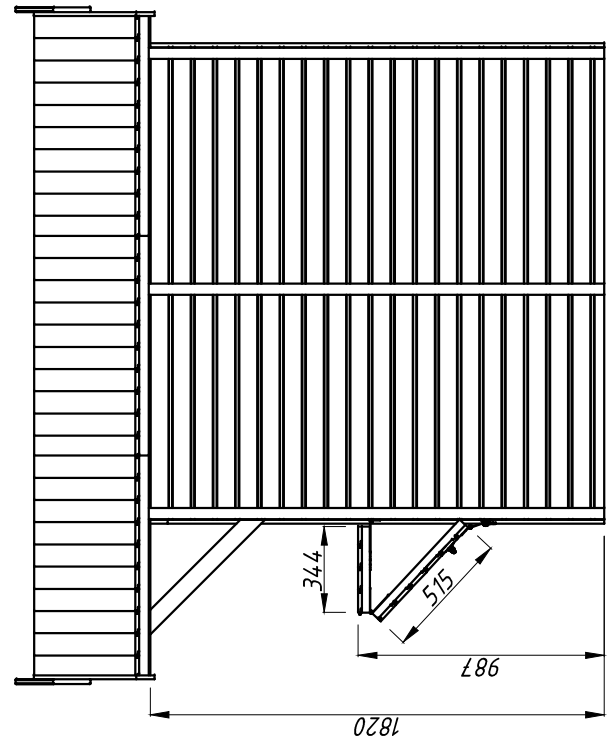
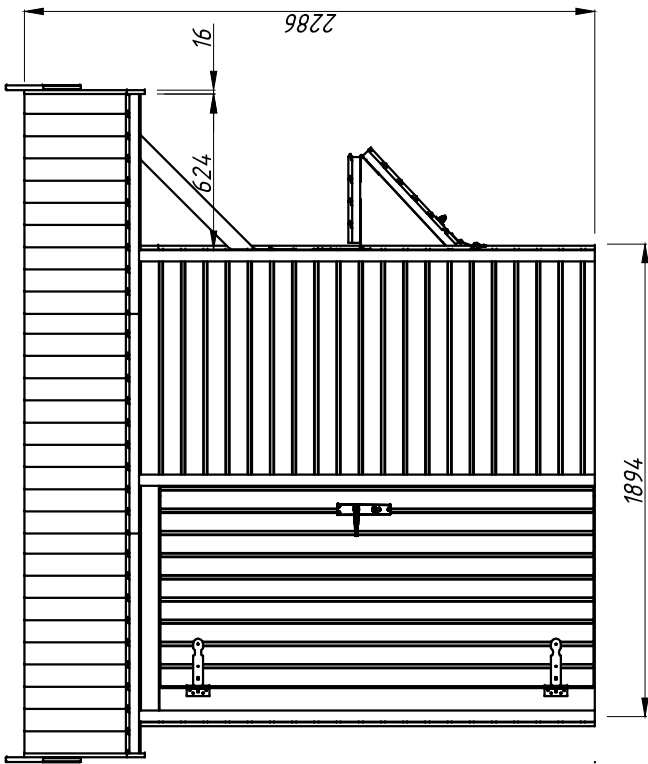



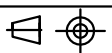
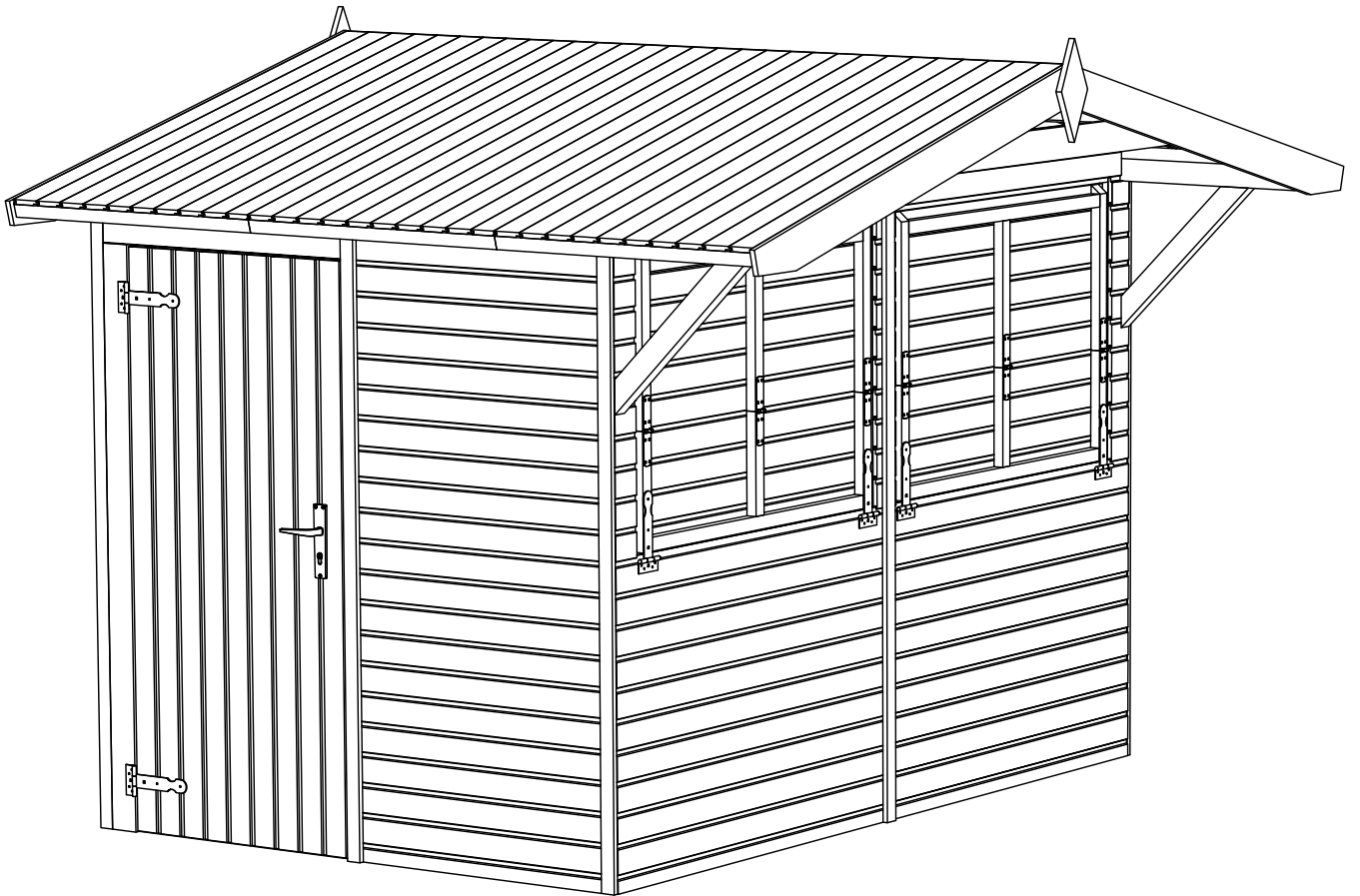





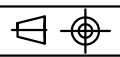
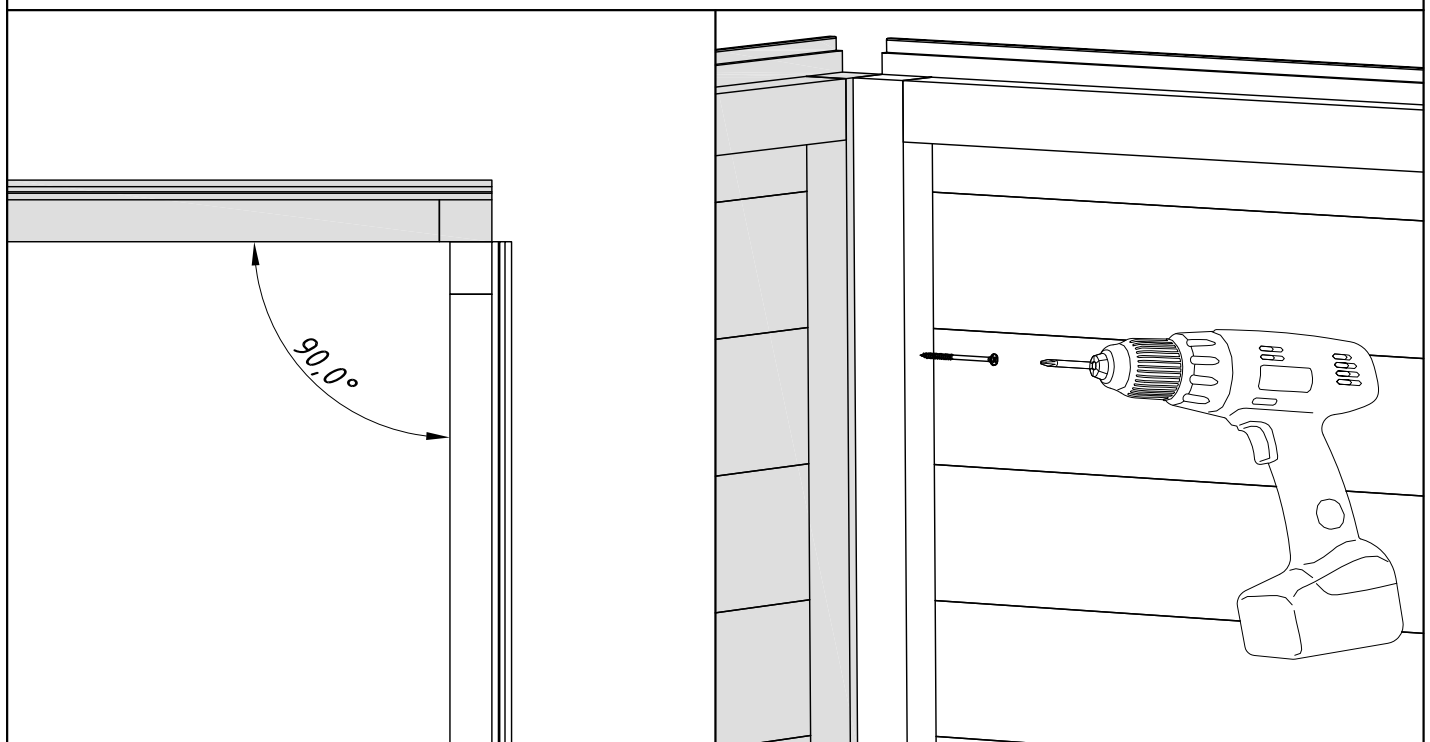
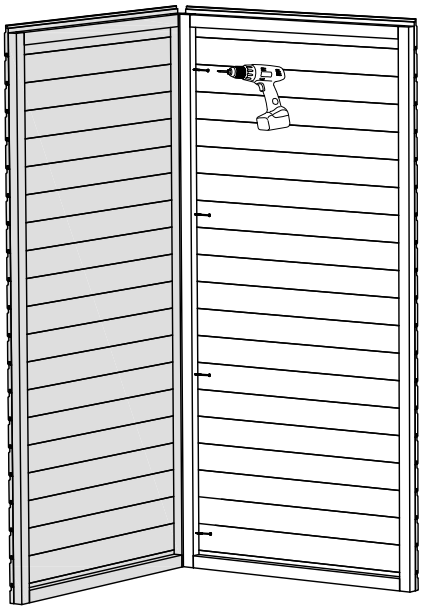
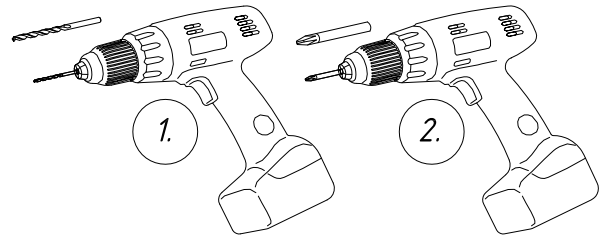

Wel-1 2 pcs  
4,5x70 5 pcs



- Wel-1      4      pcs
- Wel-2      1      pcs
- 4,5x70    25    pcs 
-       1      pcs
- 3,5x25    2      pcs 

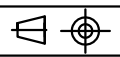
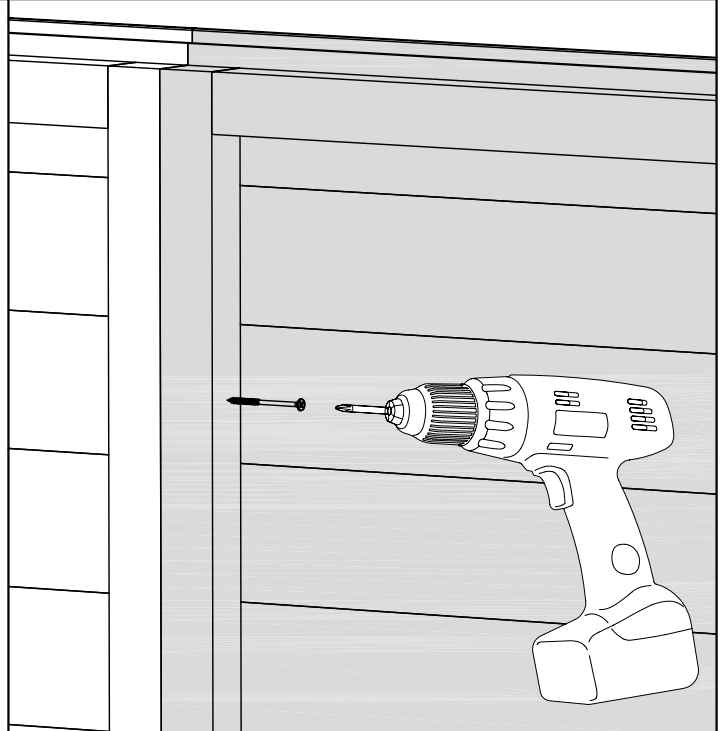
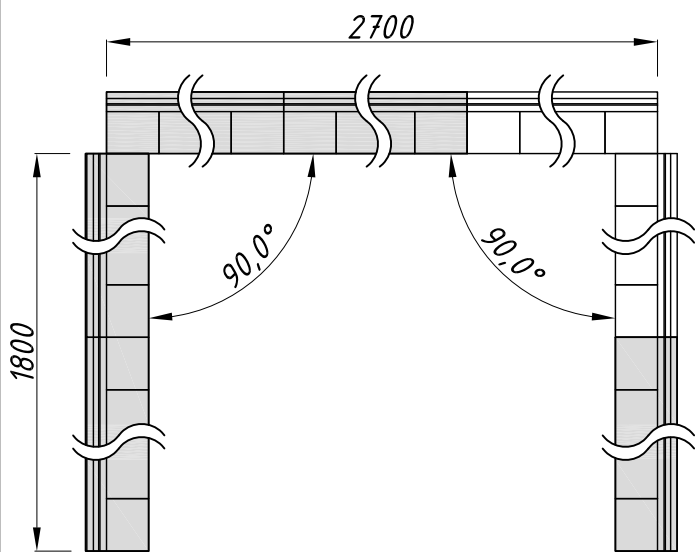
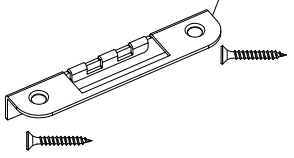
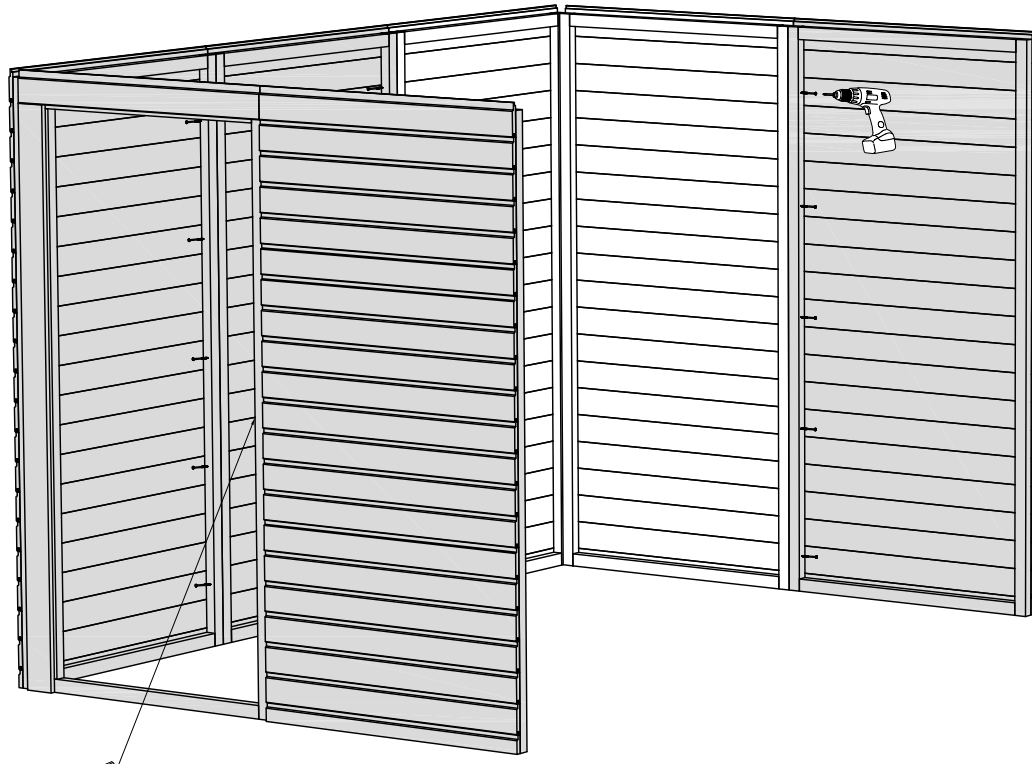
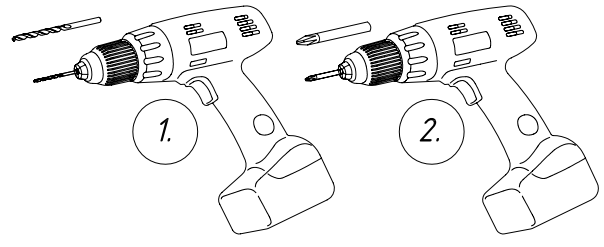

- Wel-3      2      pcs
- Wel-4      3      pcs
- CnB3       1      pcs
- 4,5X60    12    pcs
- 4,5x70    15    pcs

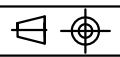
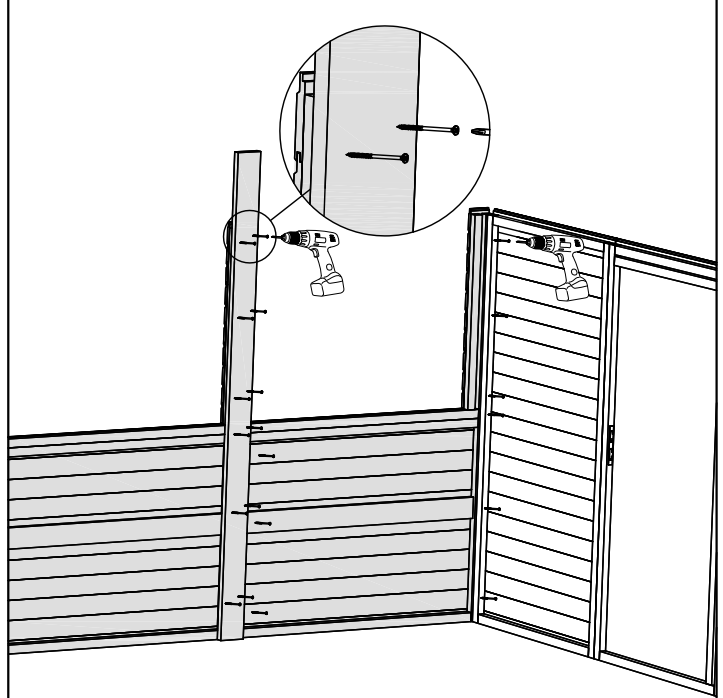
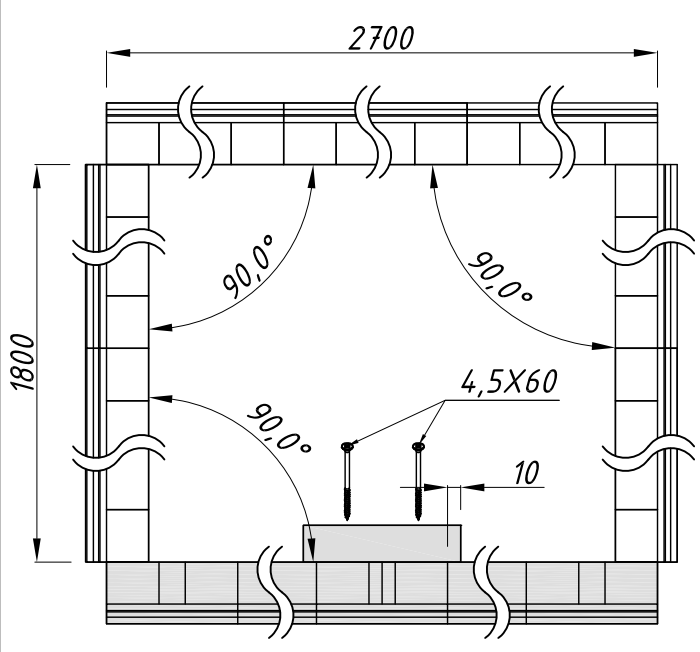
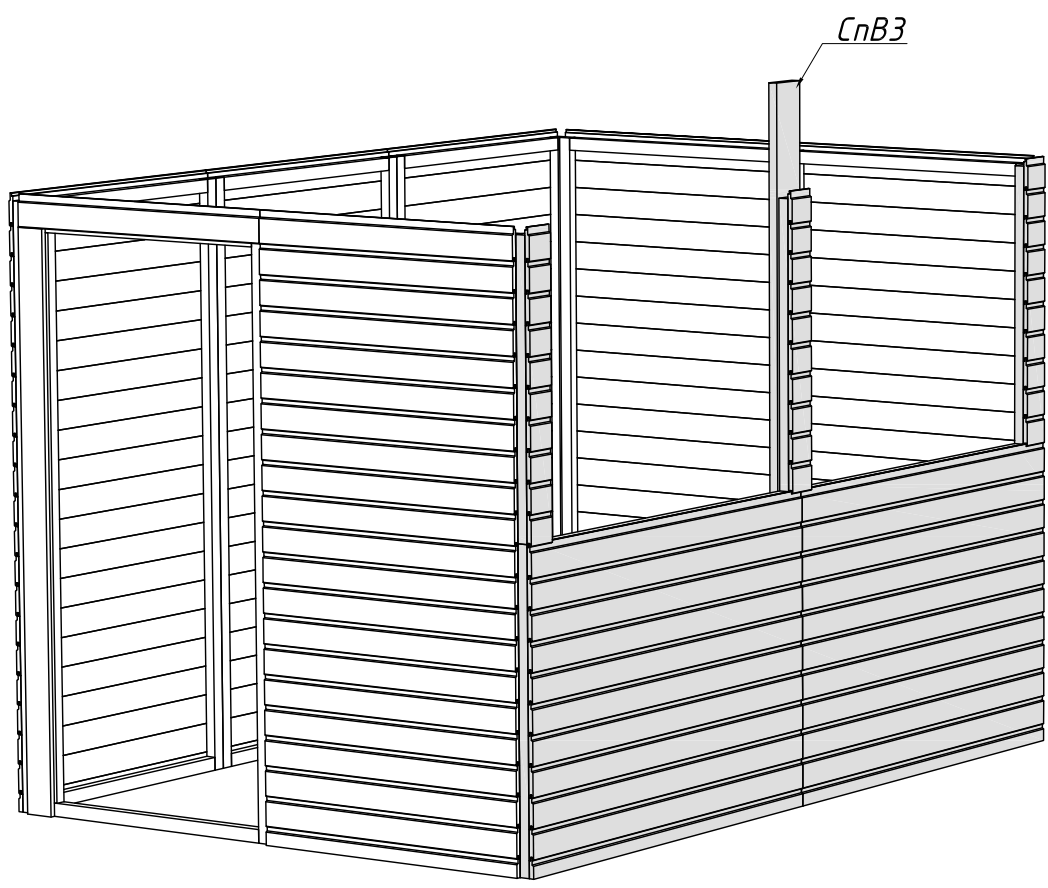
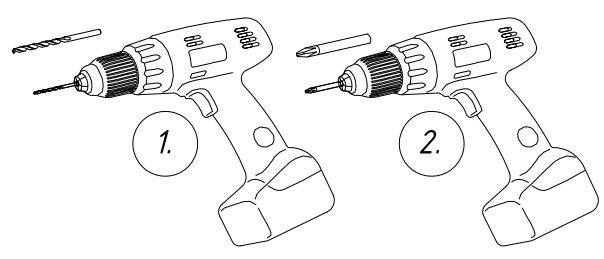

- Wel-5      1      pcs
- Wel-6      1      pcs
- CnB2       2      pcs
- 4,5X50    2      pcs
- 4,5x70    12     pcs

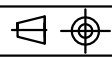
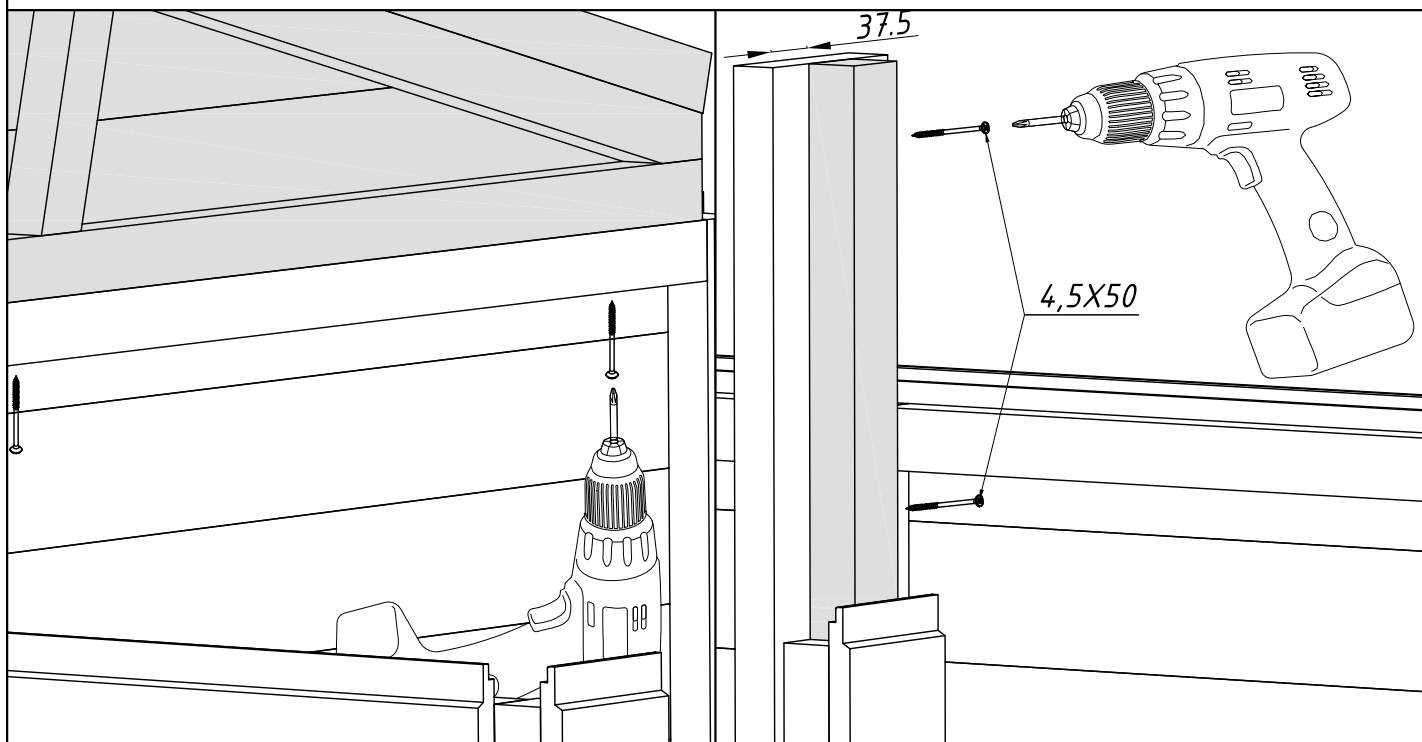
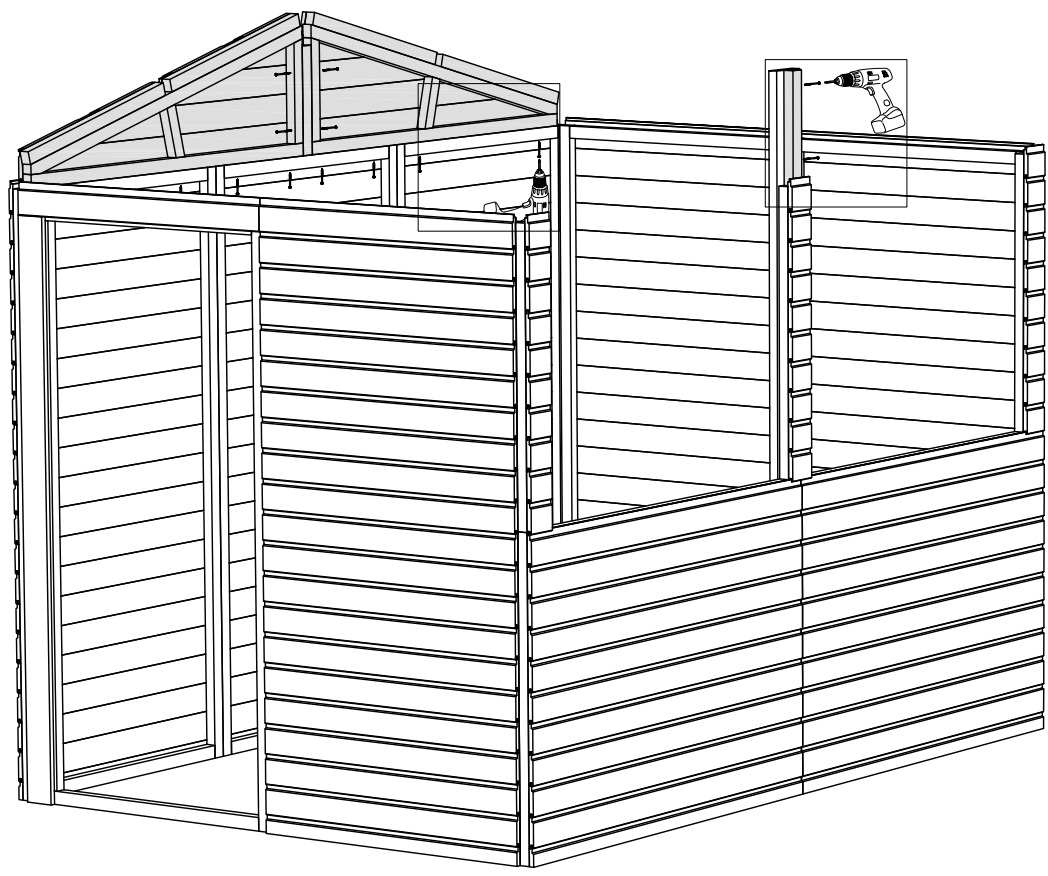
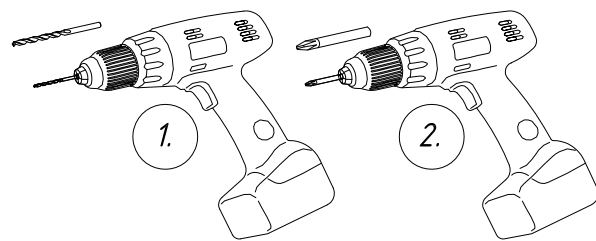

BM1 2 pcs  
 BM2 2 pcs  
 5X90 14 pcs

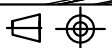
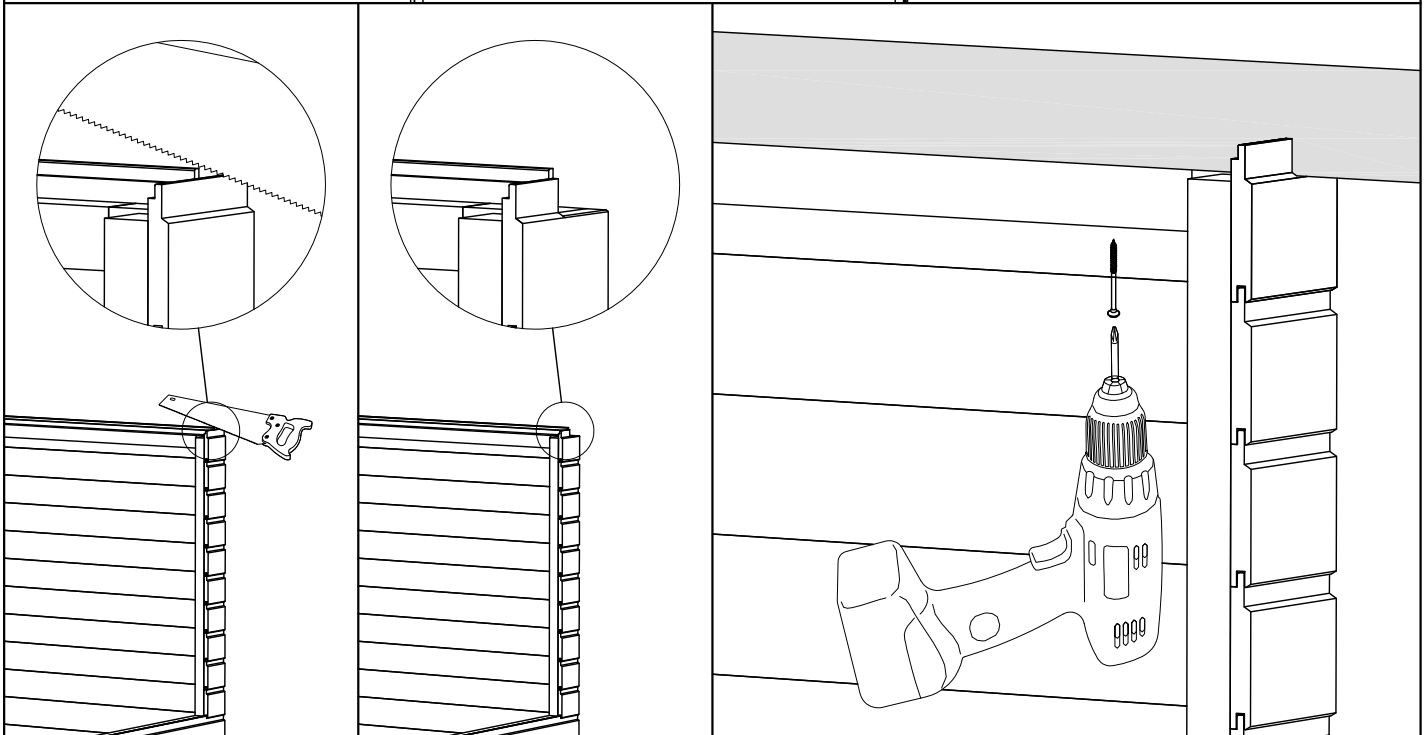
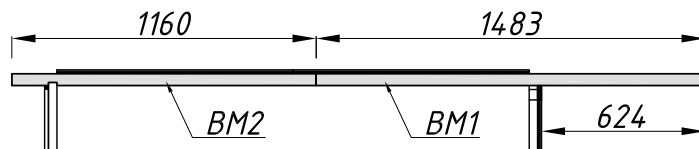
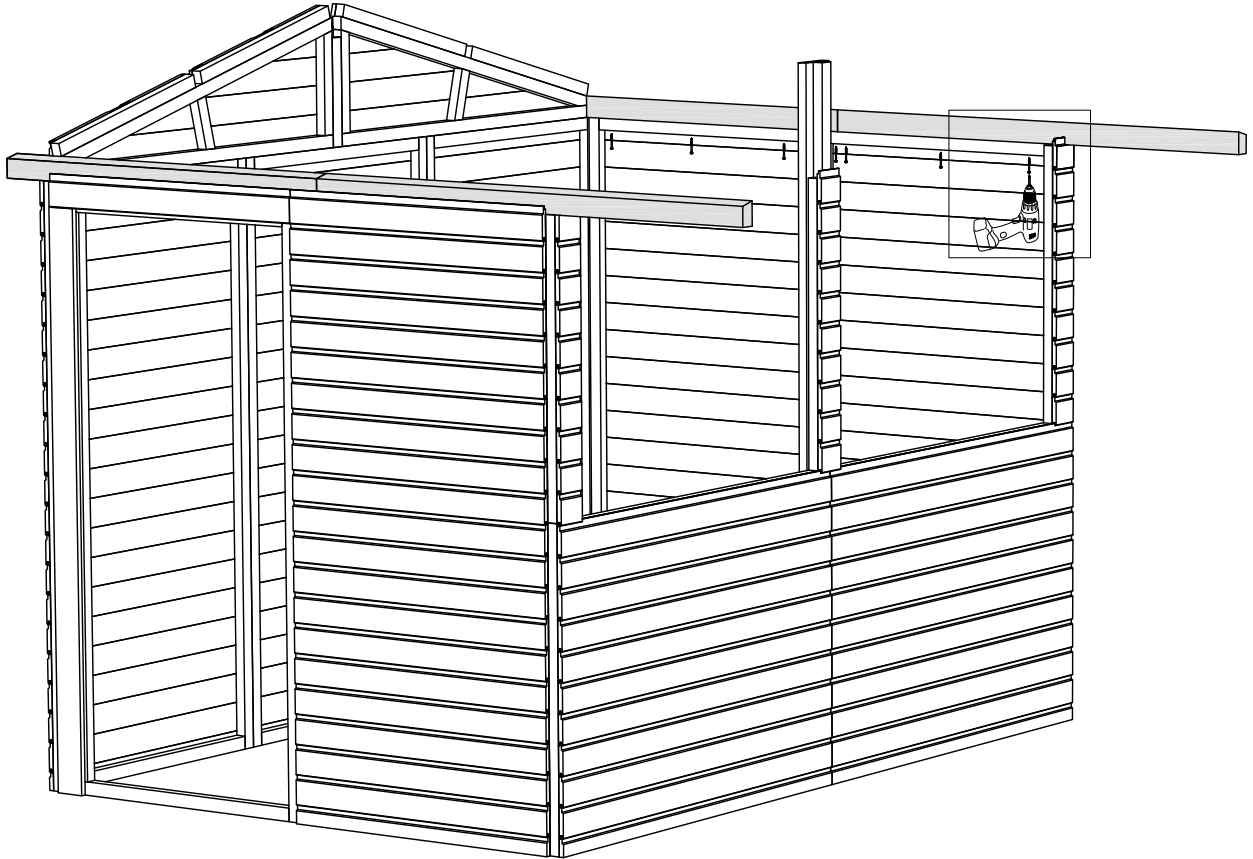
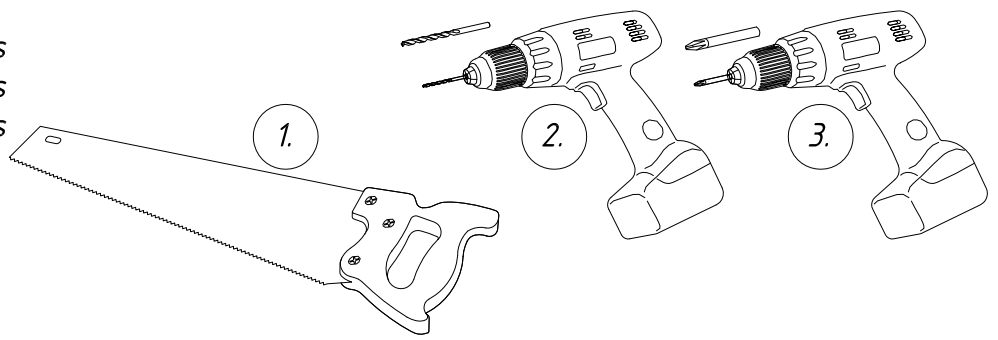

- Wel-5 1 pcs
- Wel-6 1 pcs
- 4,5X60 4 pcs
- 4,5x70 10 pcs
- 5x90 4 pcs

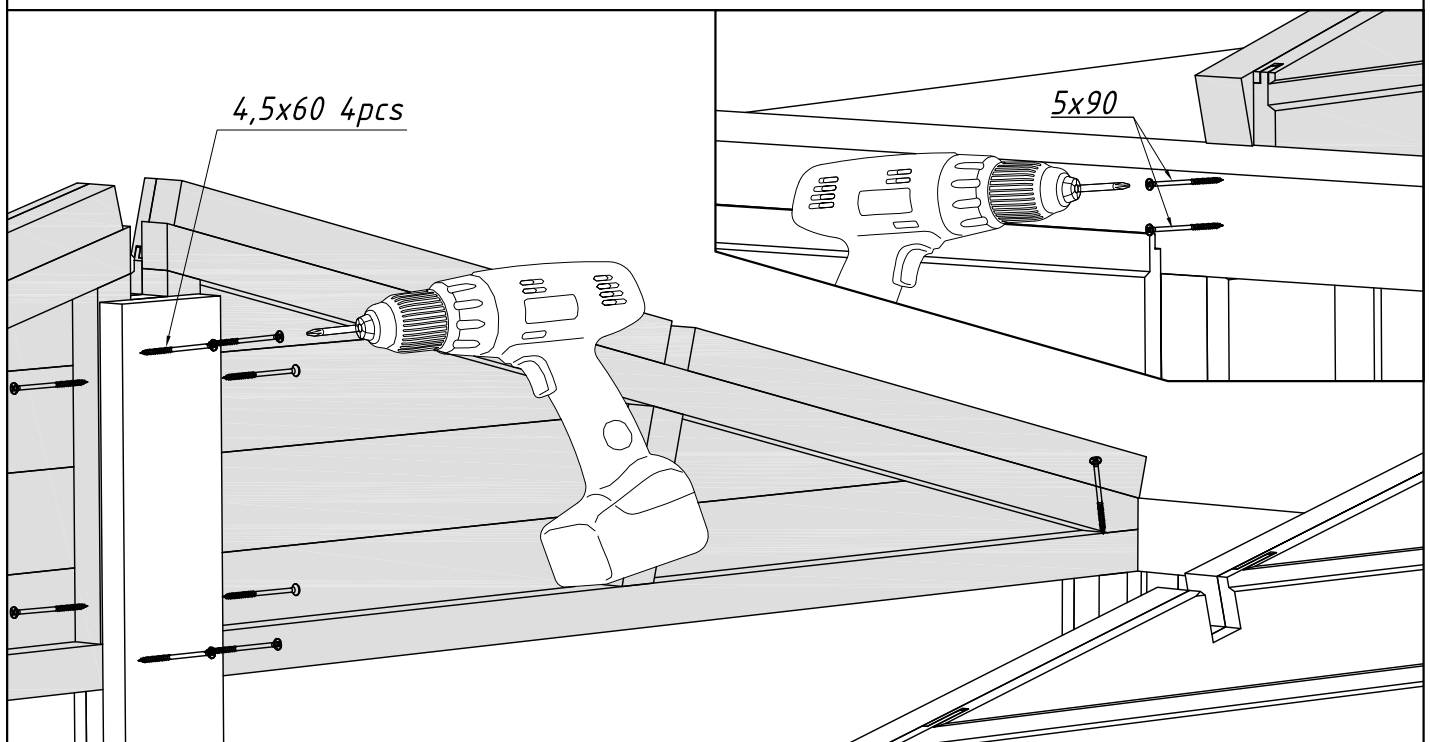
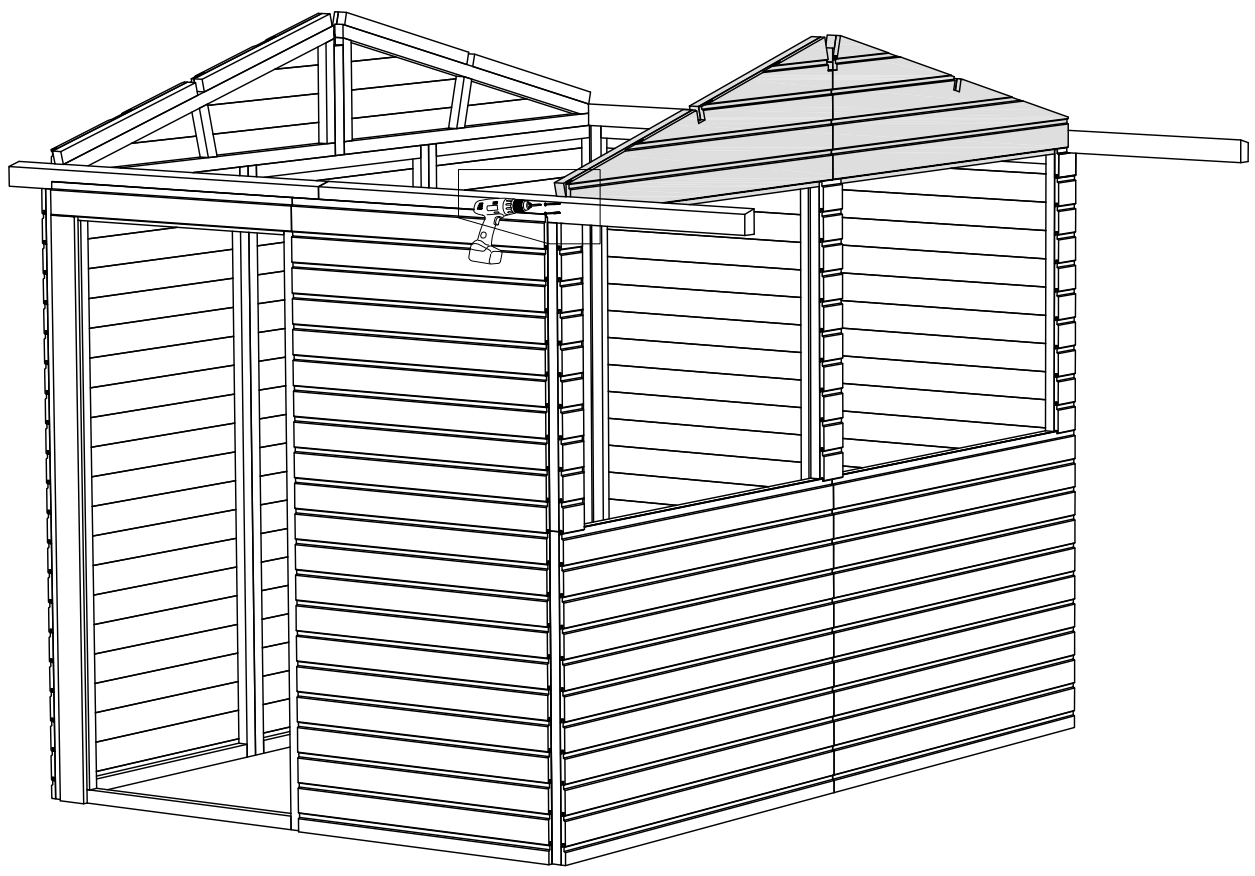
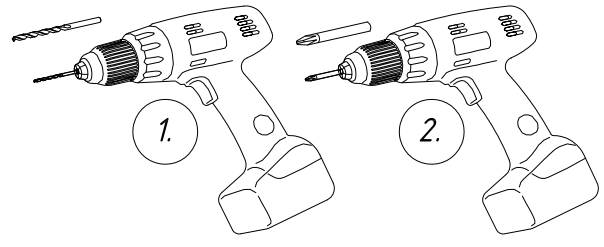





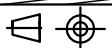
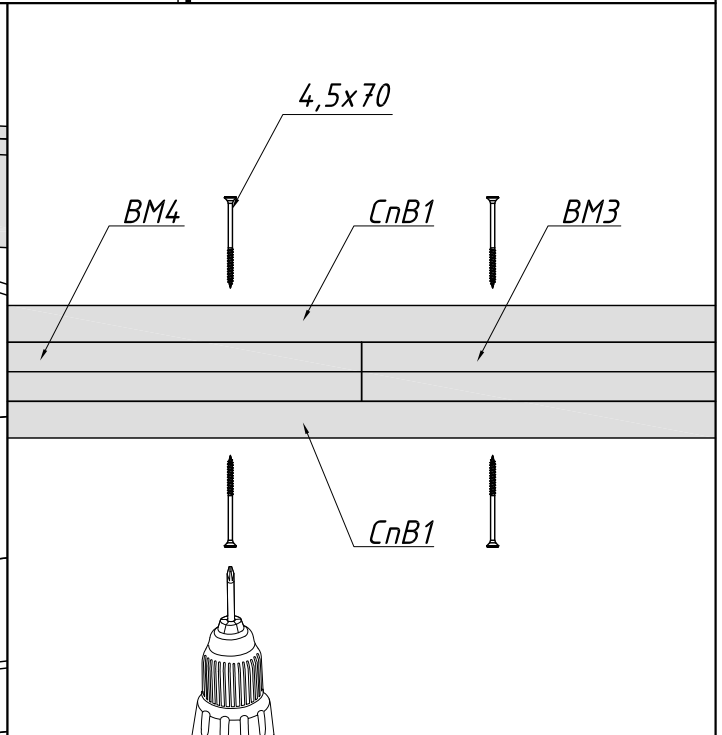
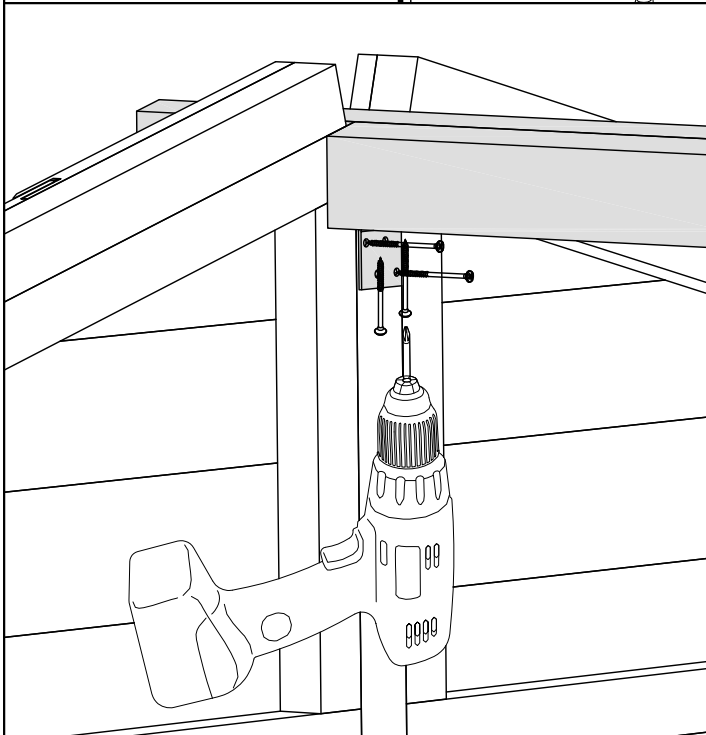
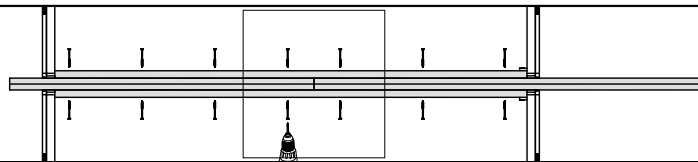
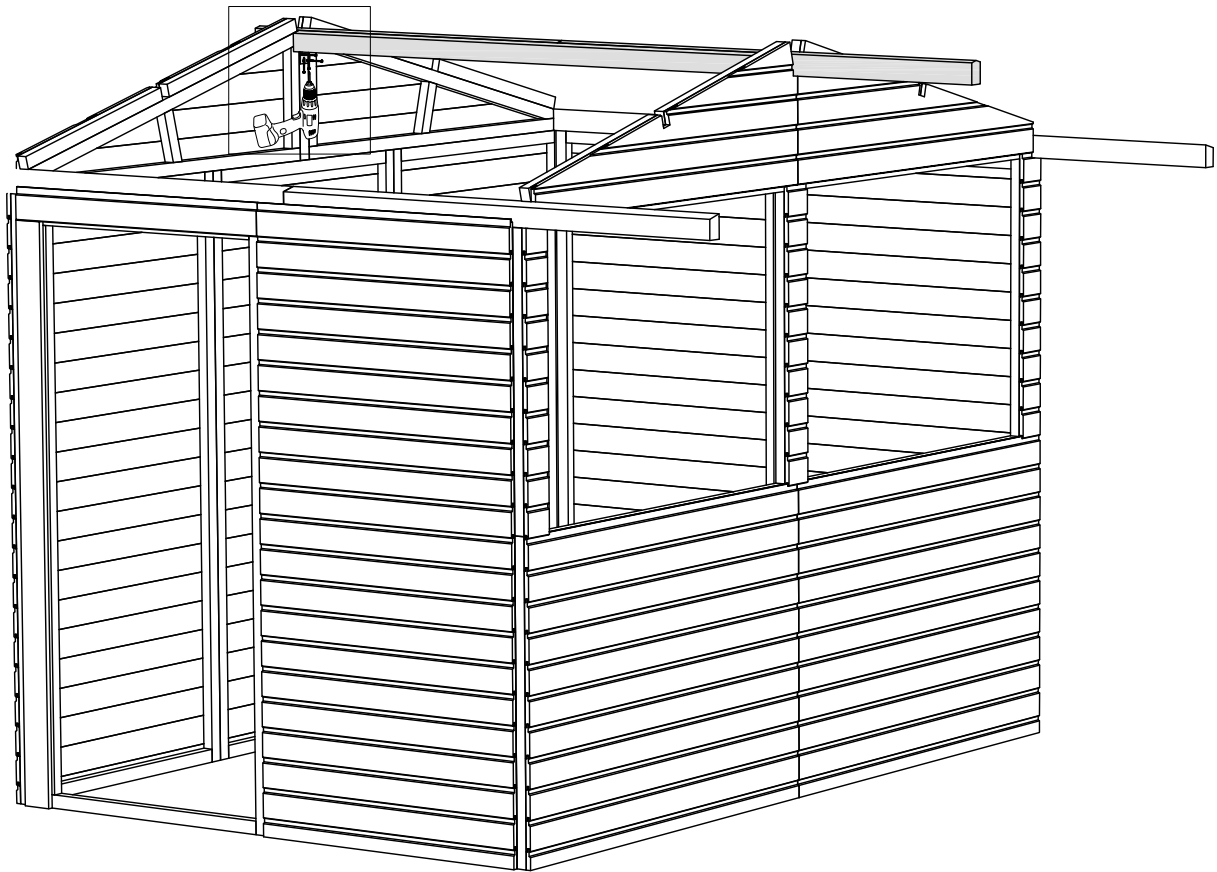
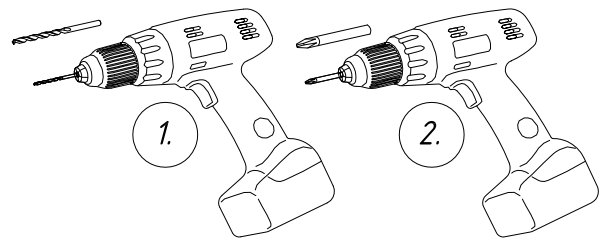

4,5x60 4pcs

5x90



BM3	1	pcs
BM4	1	pcs
CnB1	2	pcs
4,5x60	8	pcs
4,5x70	20	pcs
	2	pcs

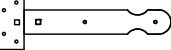

- DEL1-1      1      pcs
- 4x25        12     pcs
-       1      pcs
-         1      pcs
-       1      pcs
-     2      pcs
-     4      pcs

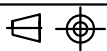
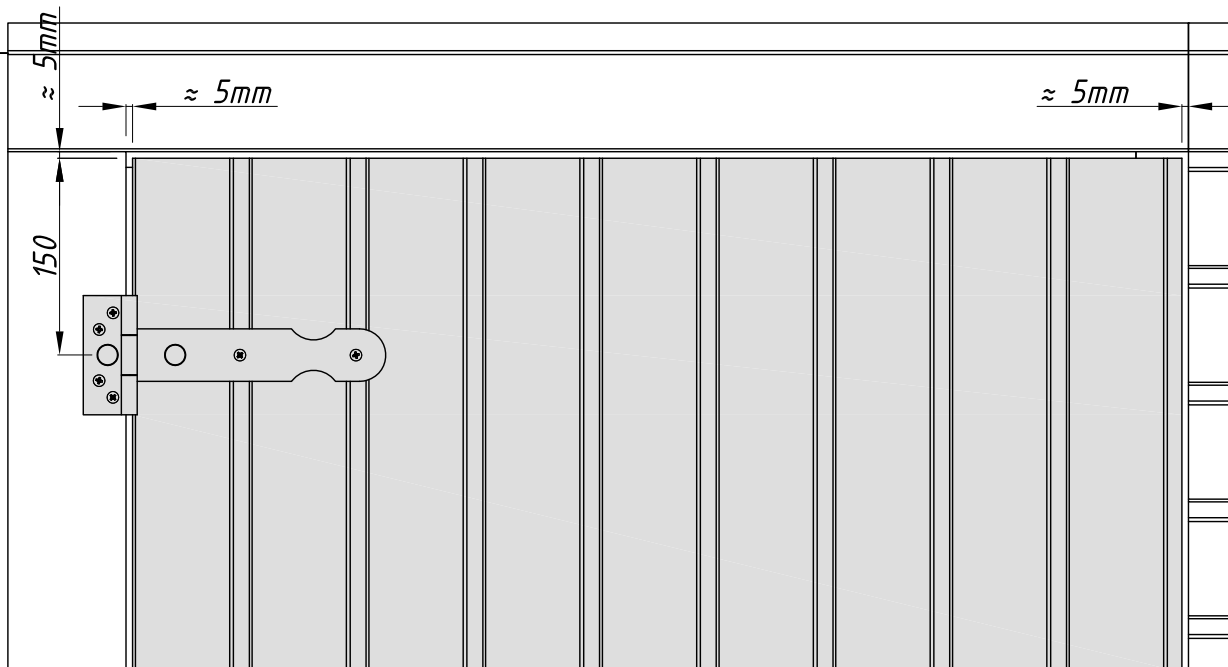
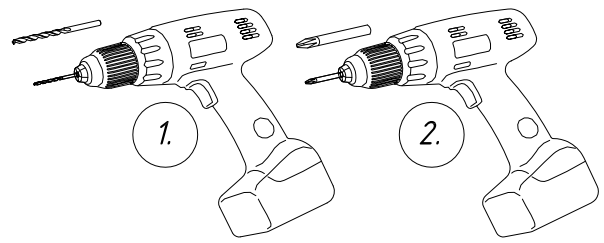



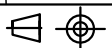
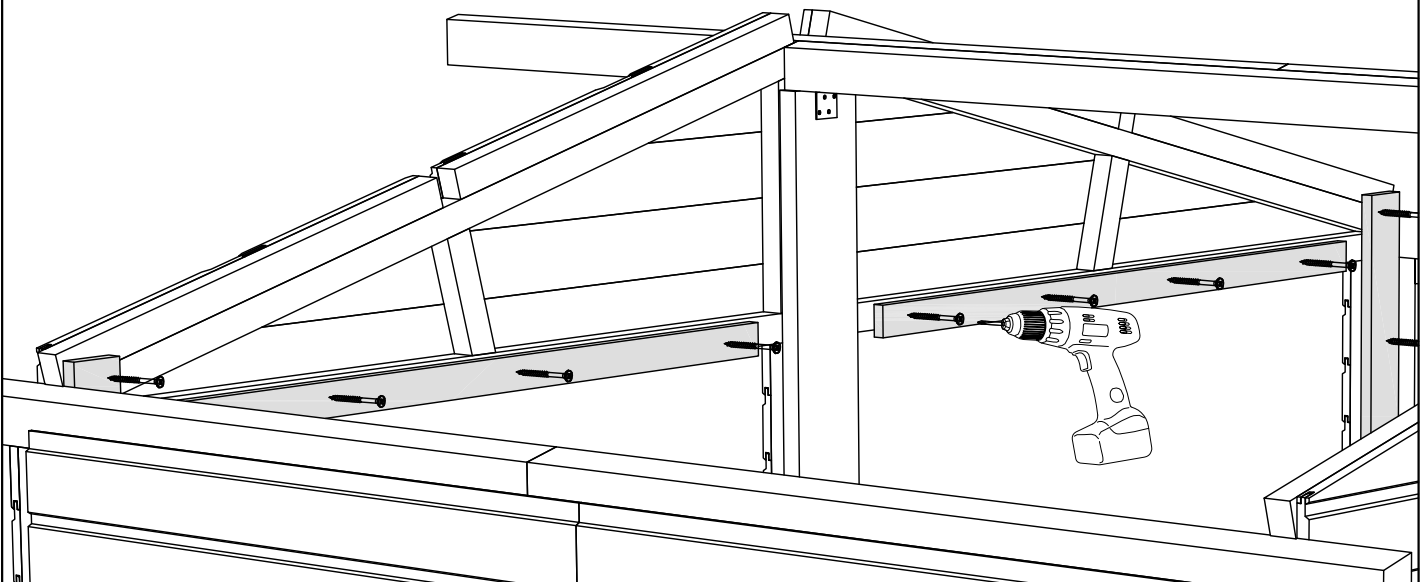
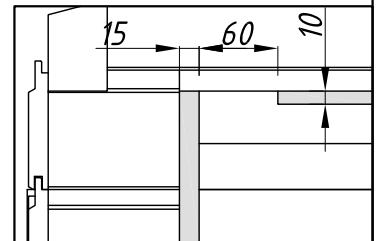
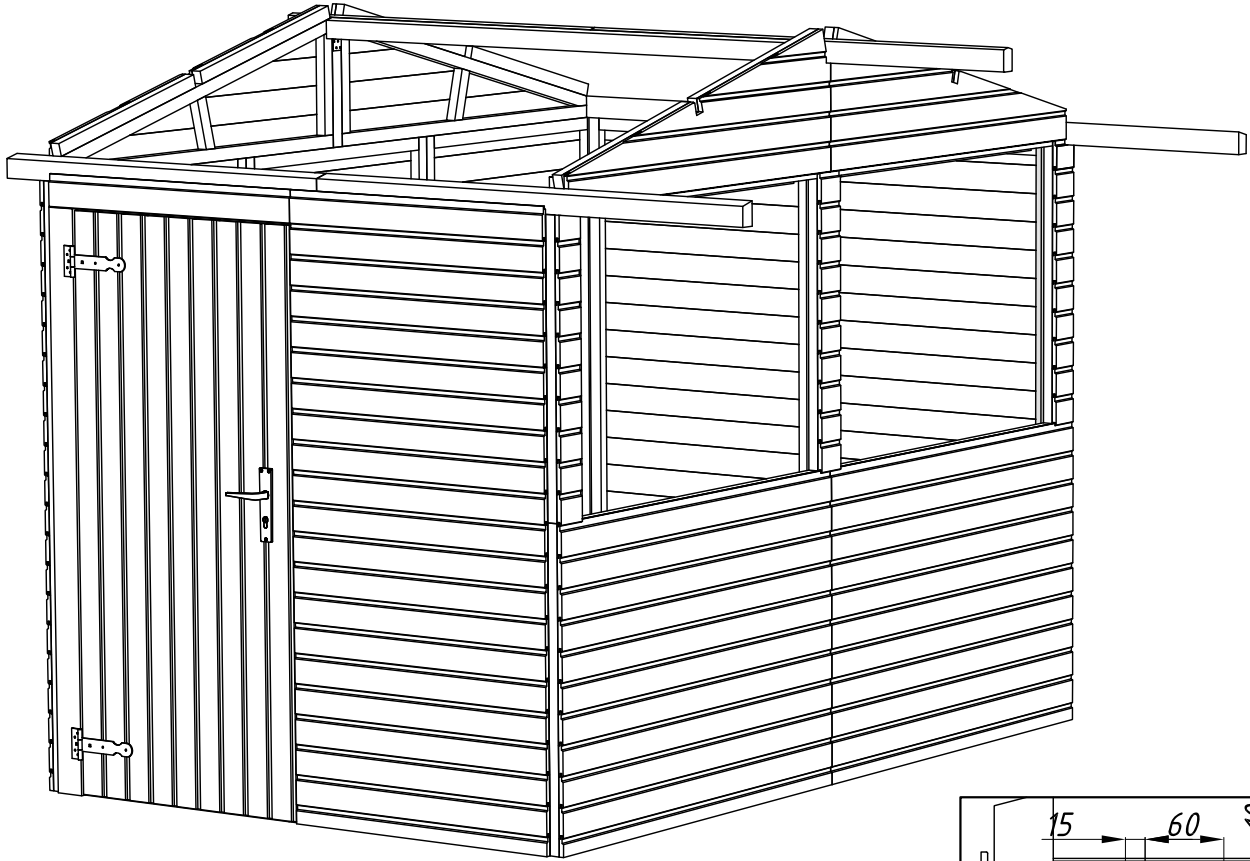
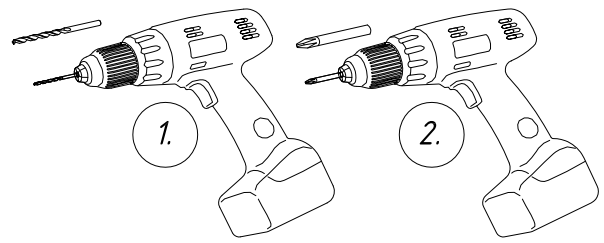

CoB3 2 pcs  
CoB5 2 pcs  
4,5X50 16 pcs

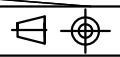
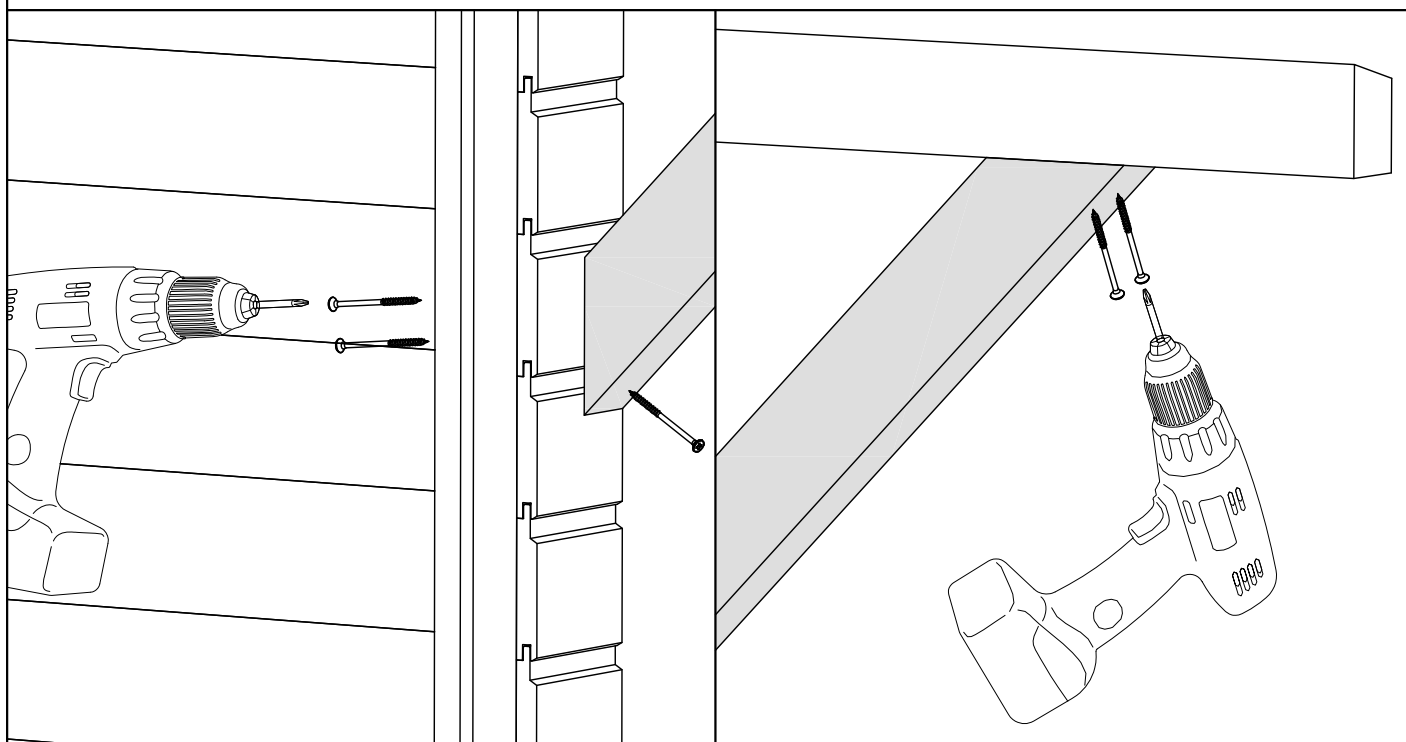
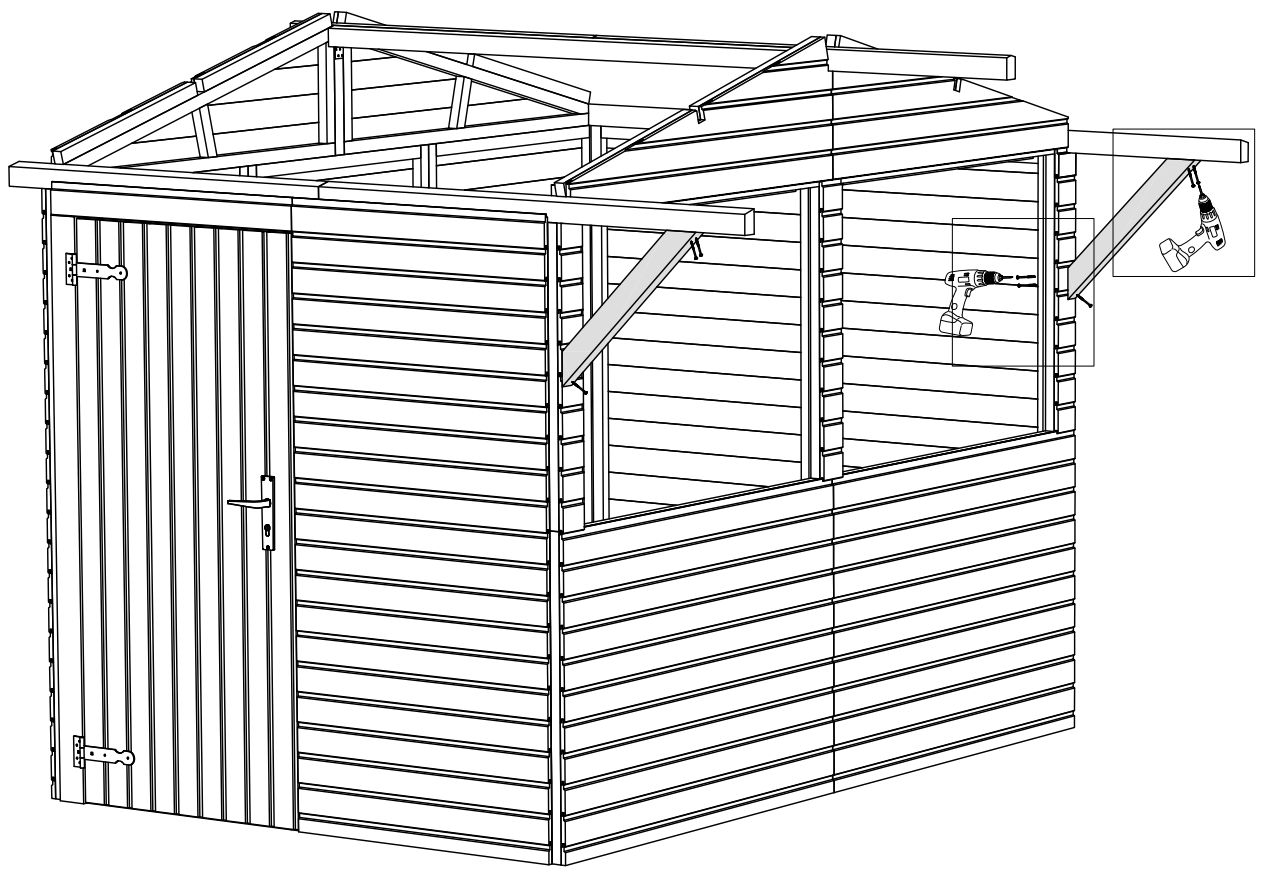
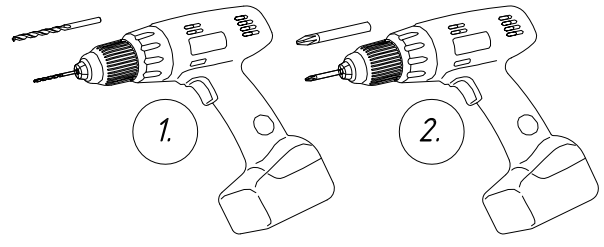

SP1  
6x120

2 pcs  
10 pcs

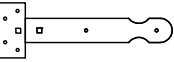

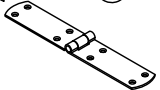
- Wel-7      2      pcs
- Wel-8      2      pcs
- 4x25      72      pcs
-  4      pcs
-  8      pcs
-  6      pcs

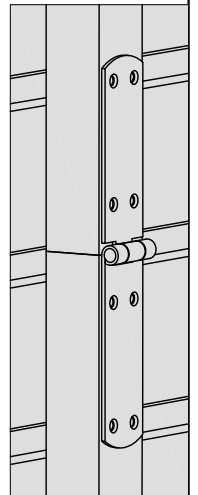
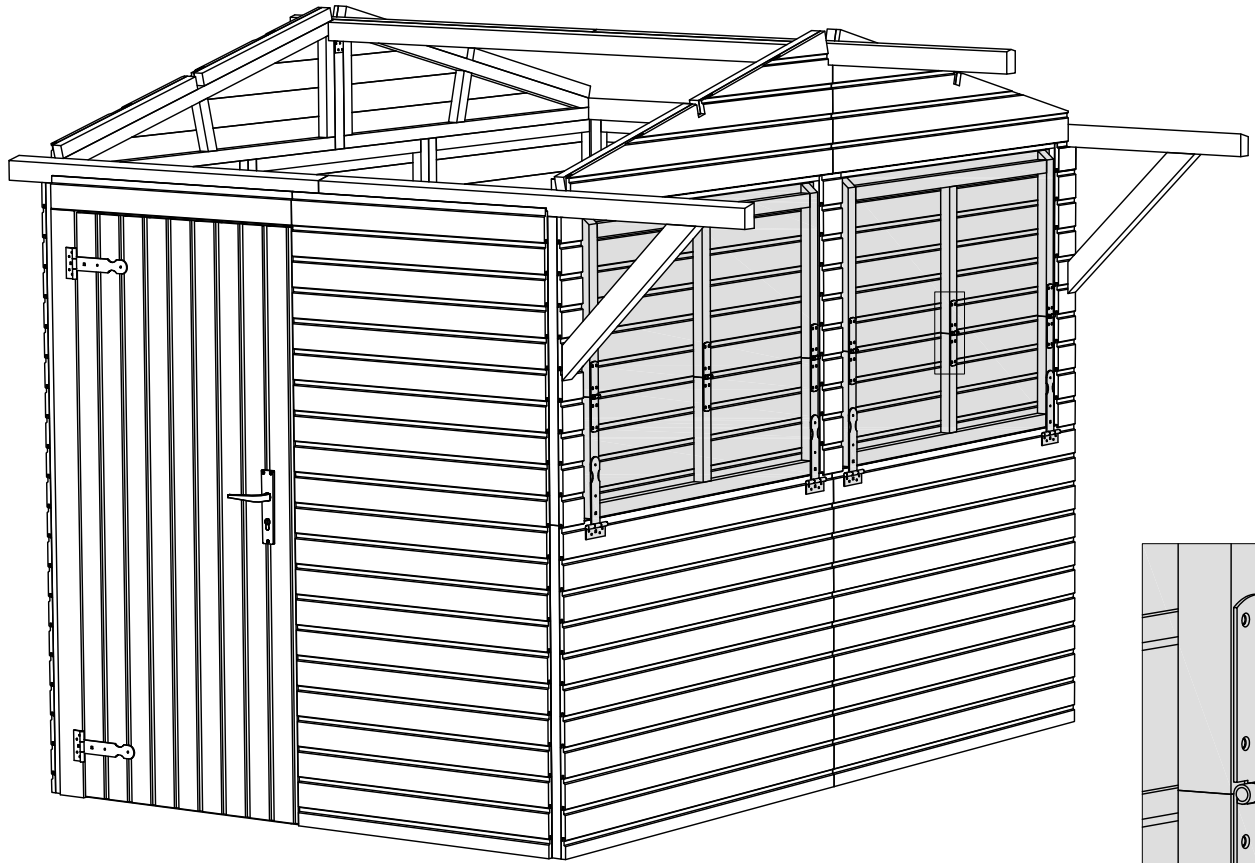
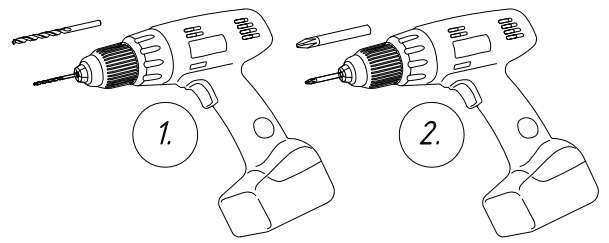

≈5

≈5

≈5

≈5

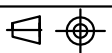
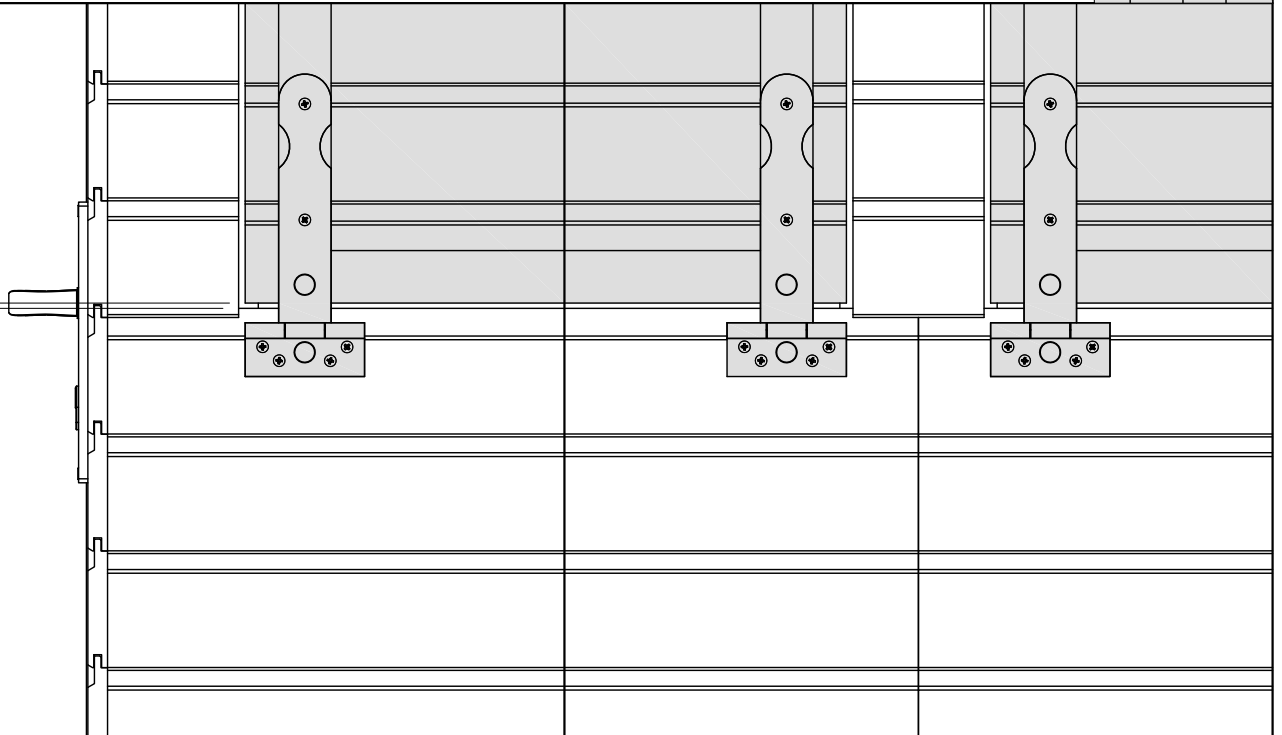

4x25

32 pcs

3x16

32 pcs

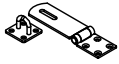



4 pcs

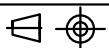
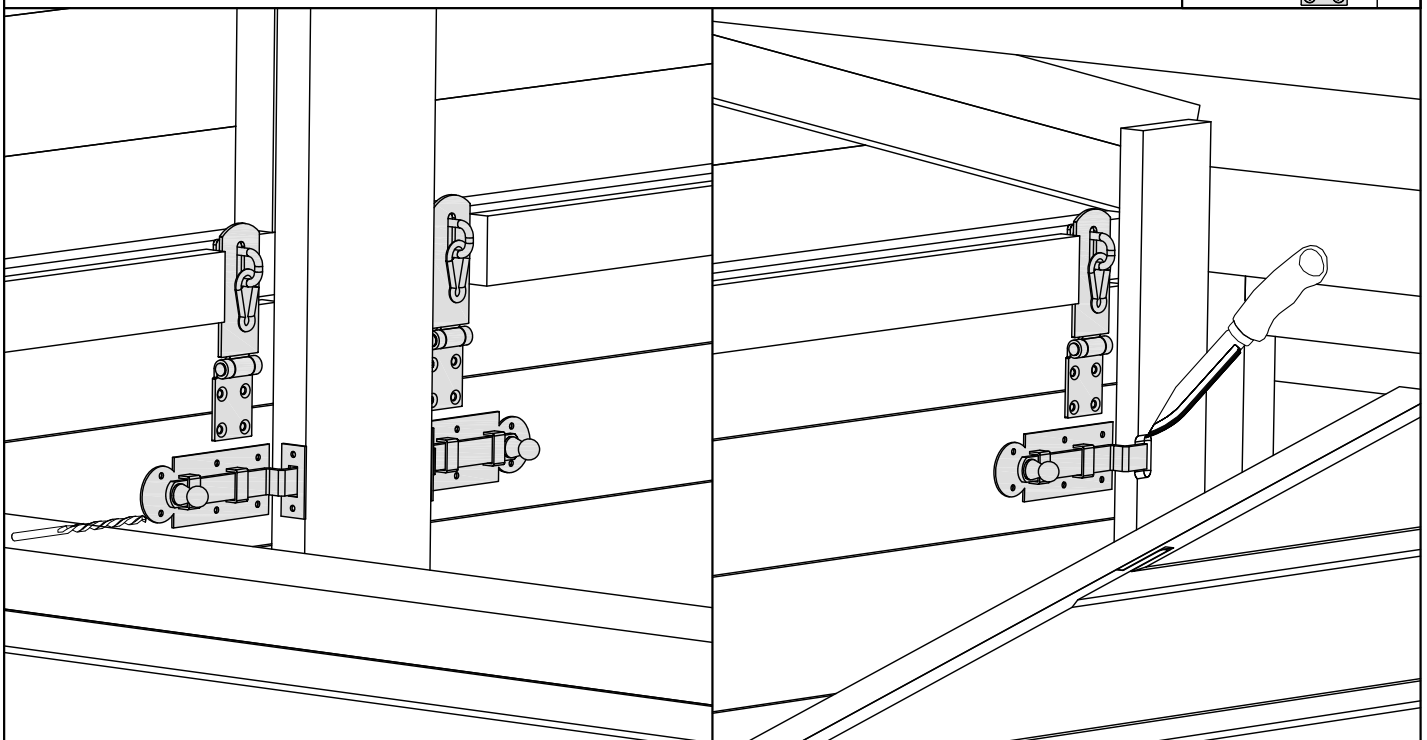
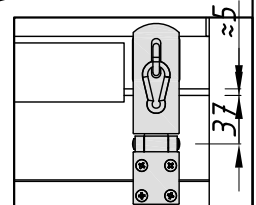
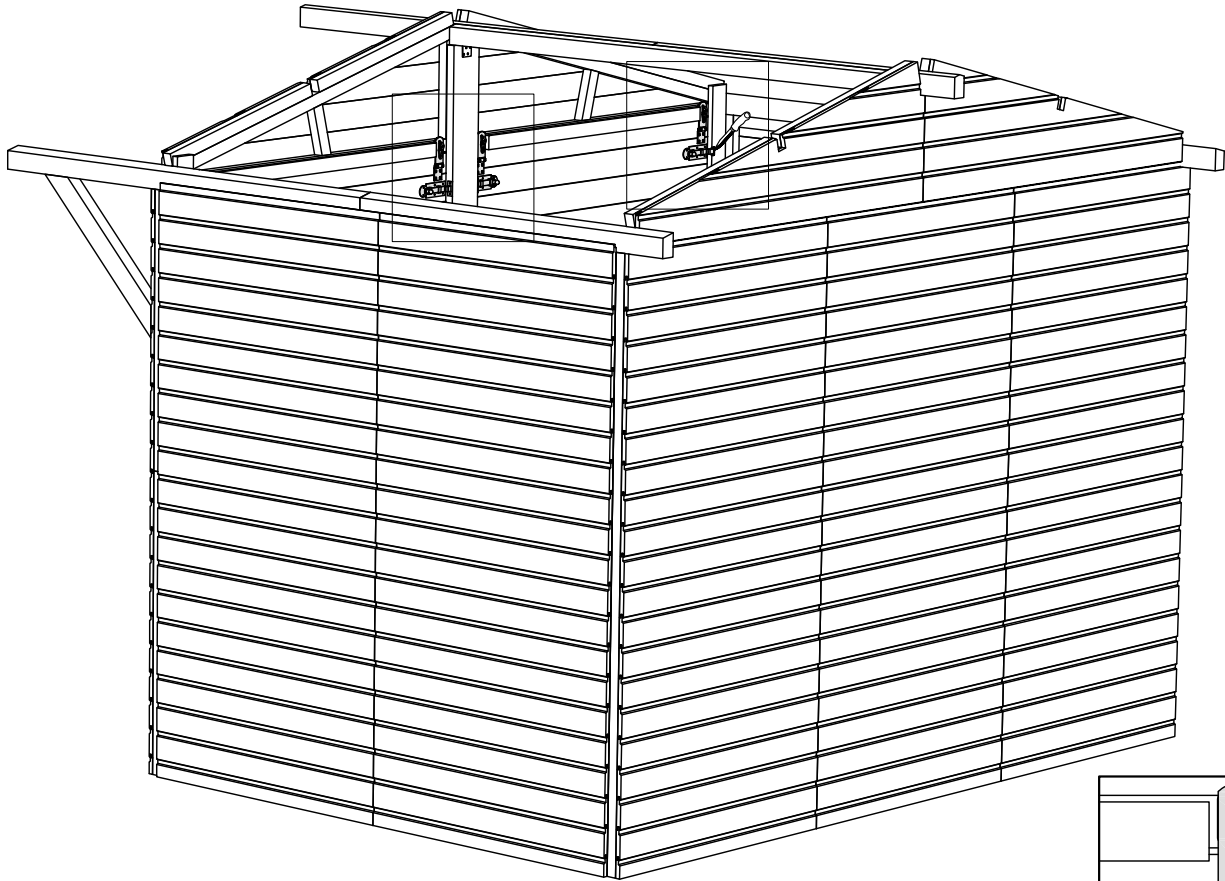
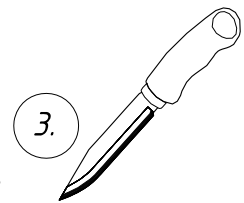
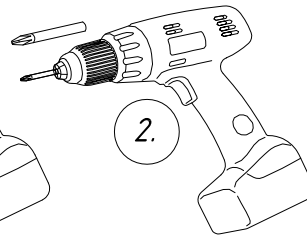
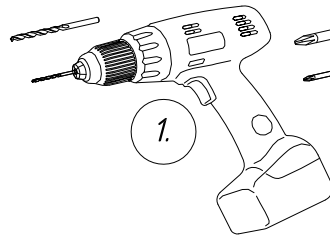

4 pcs



- 4x25      16    pcs
-       4    pcs
-       4    pcs

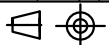
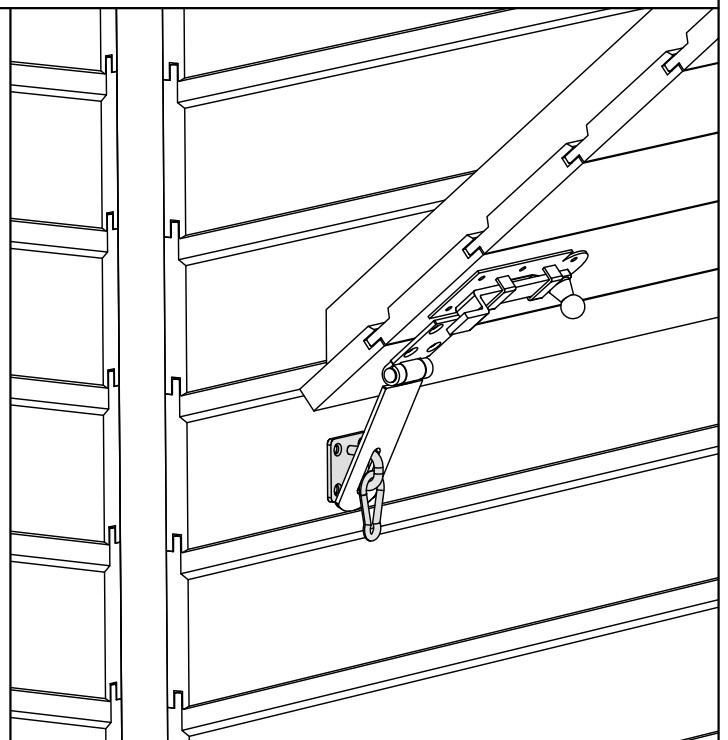
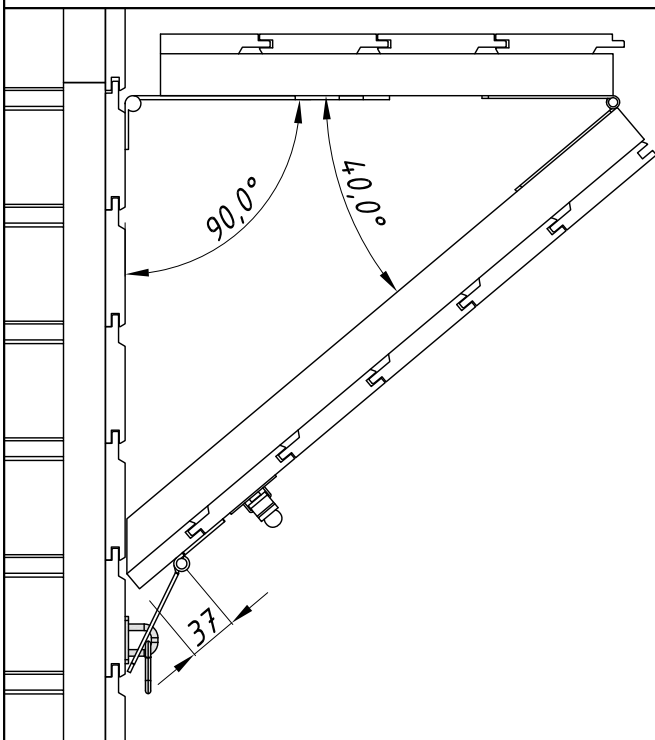
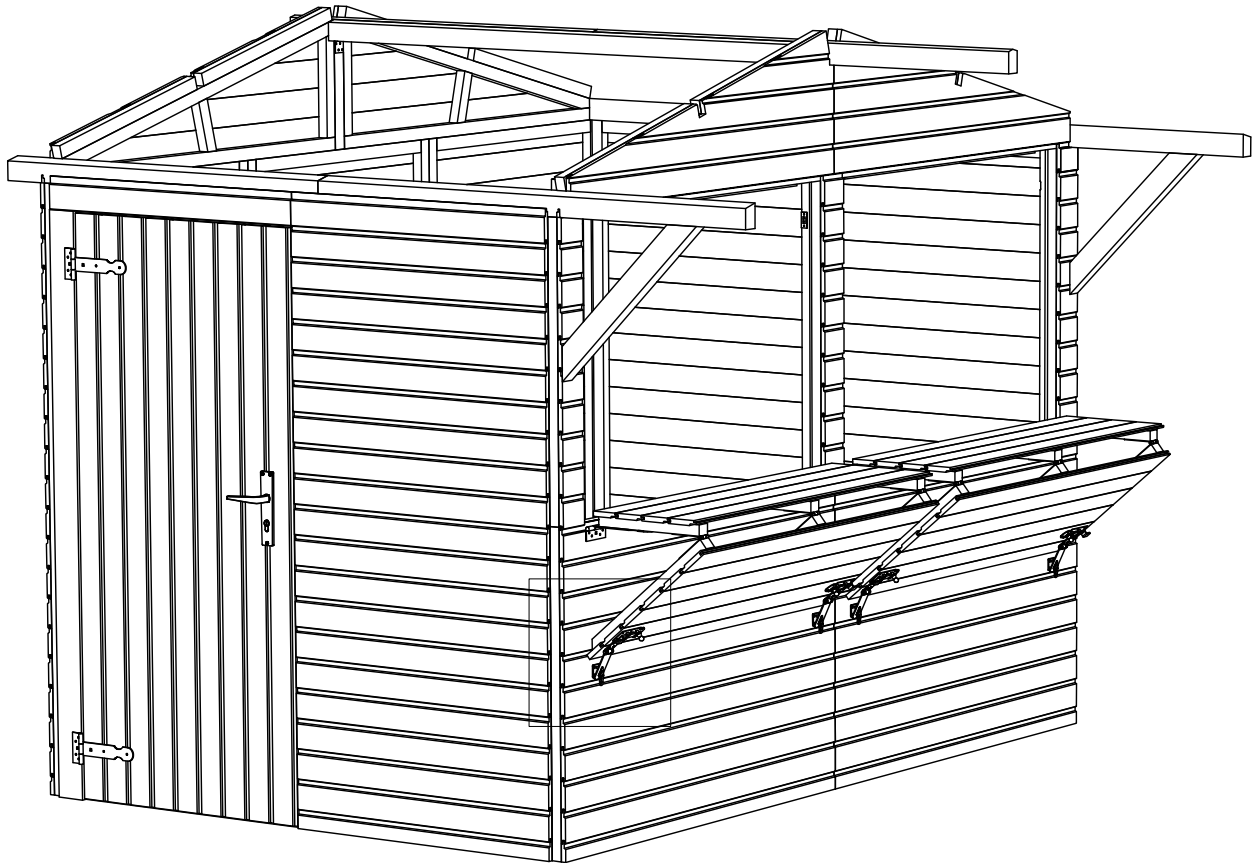
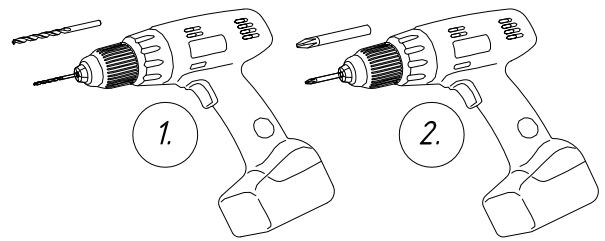

Rel1-1      3      pcs  
 4,5x50      4      pcs  
 6x120      18      pcs

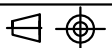
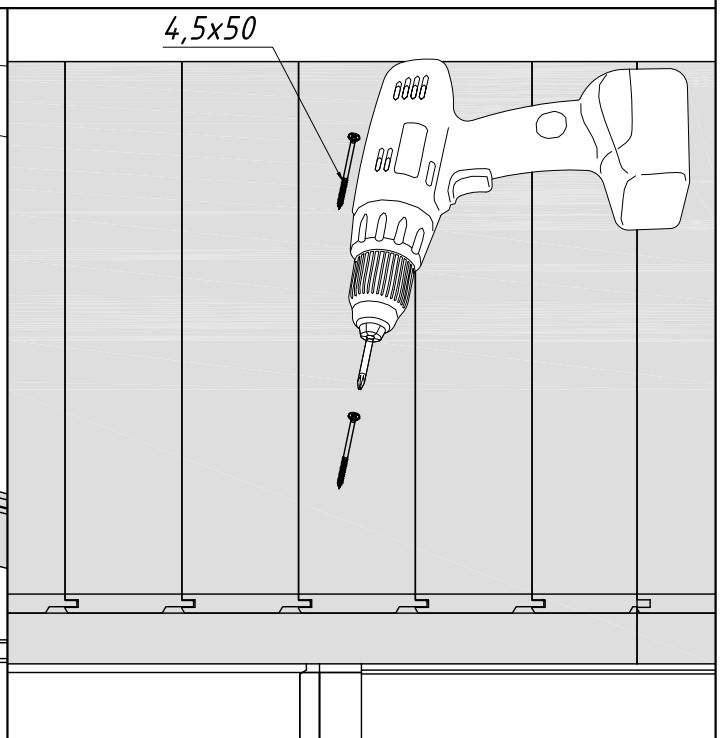
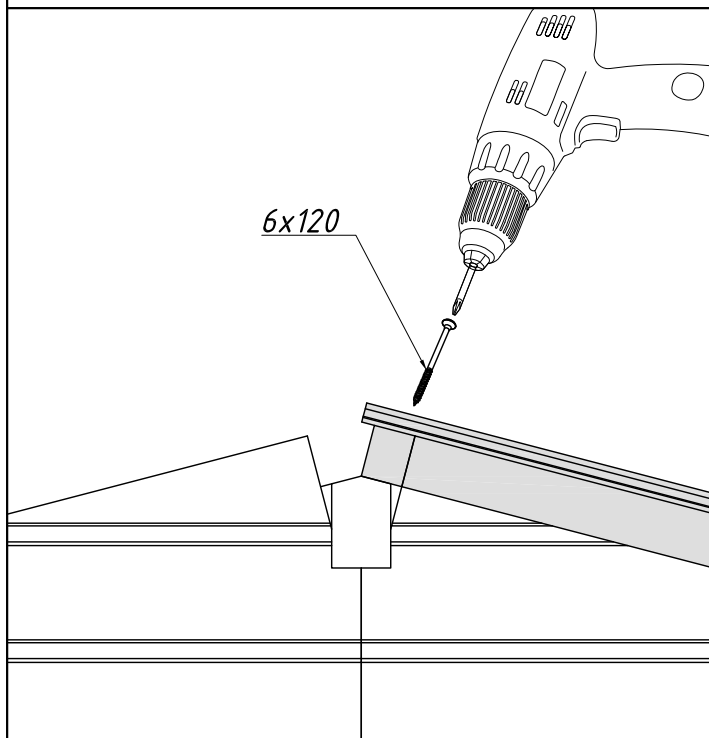
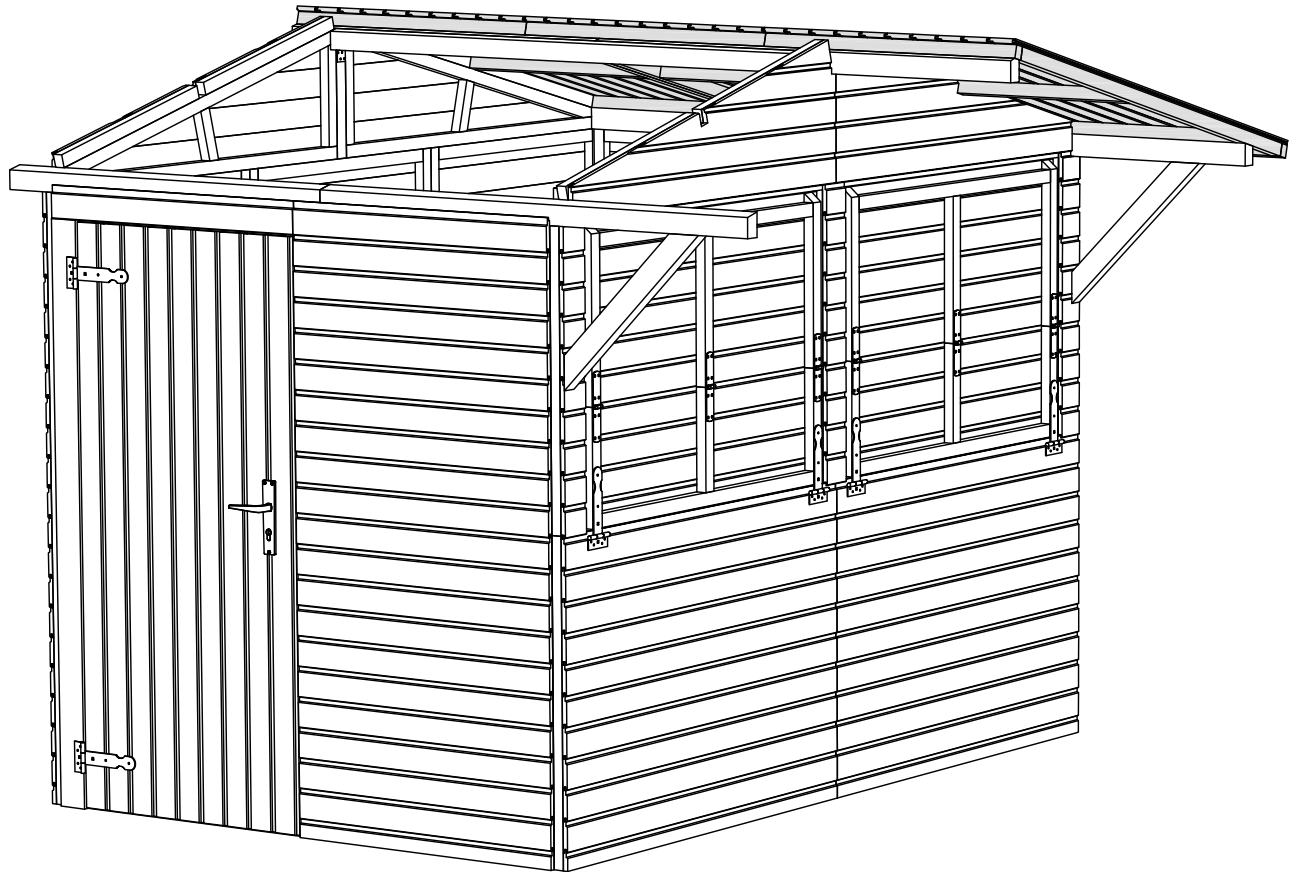
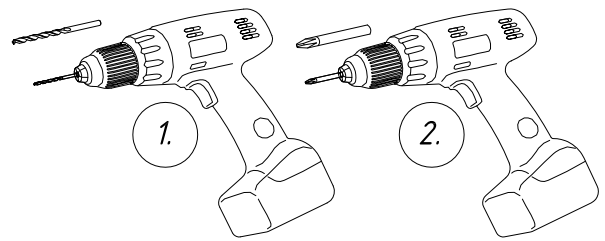

Rel1-1 3 pcs  
 4,5x50 4 pcs  
 6x120 18 pcs

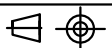
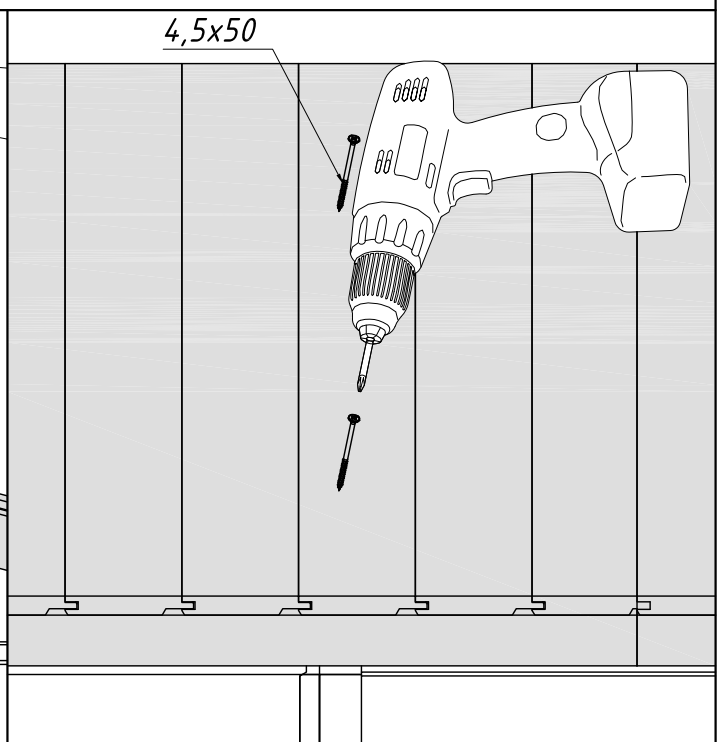
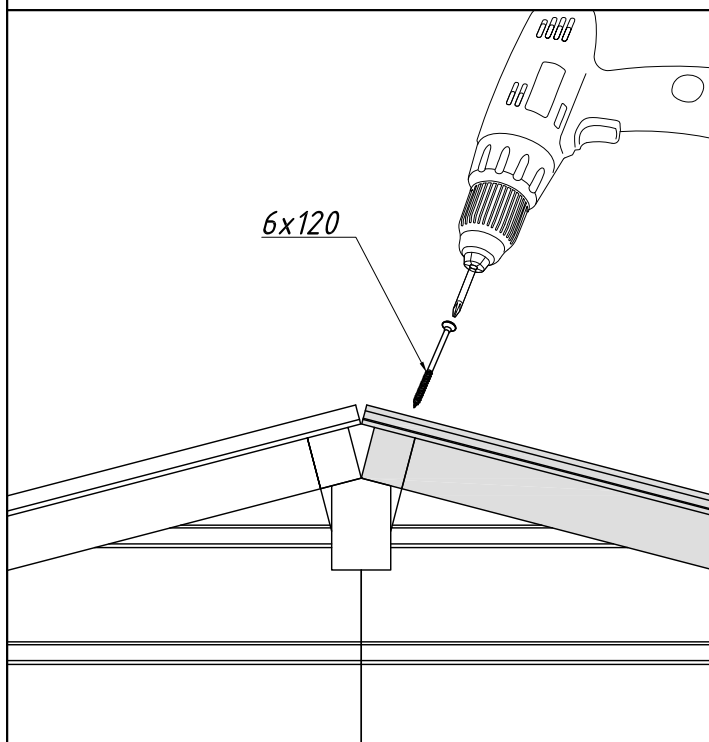
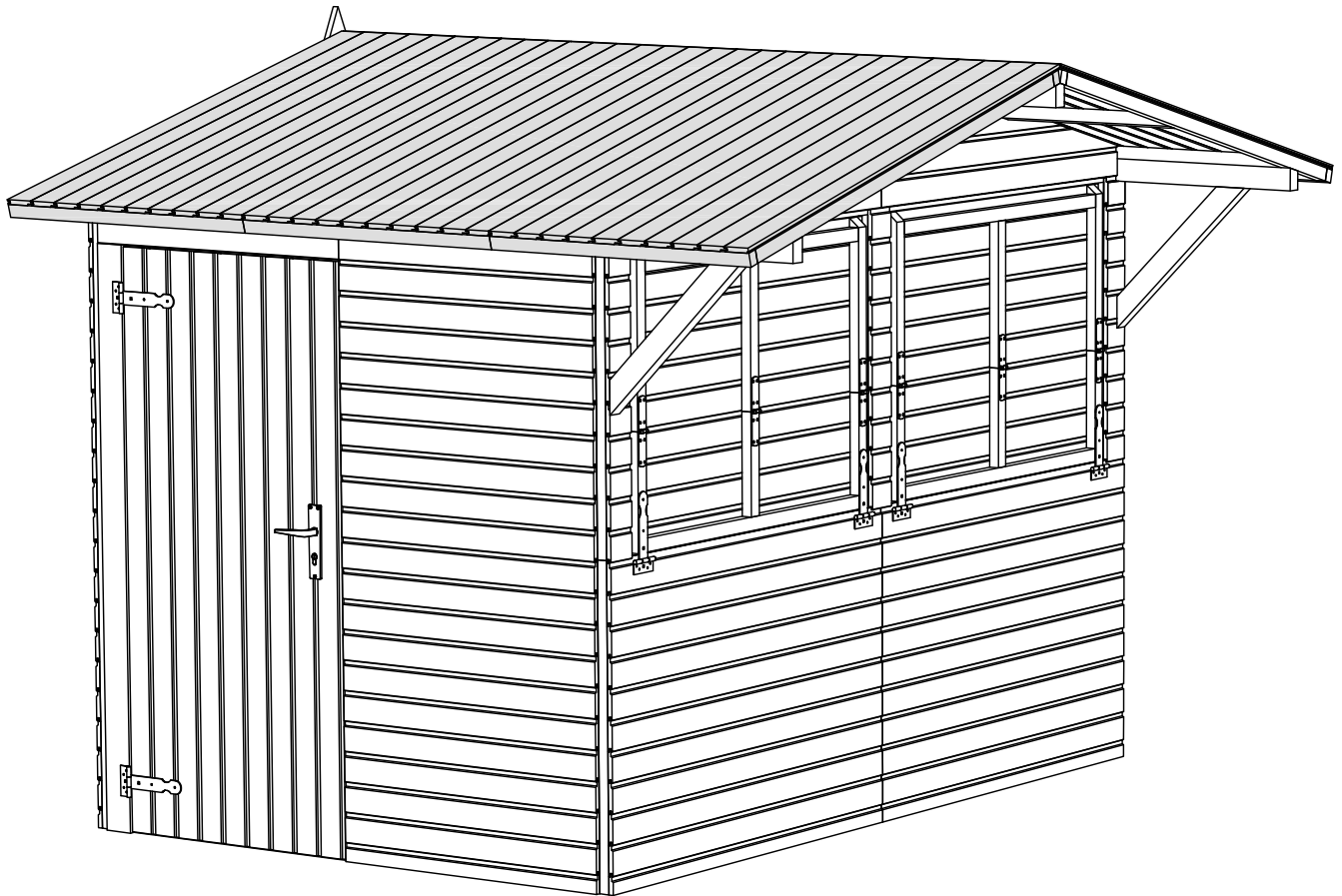
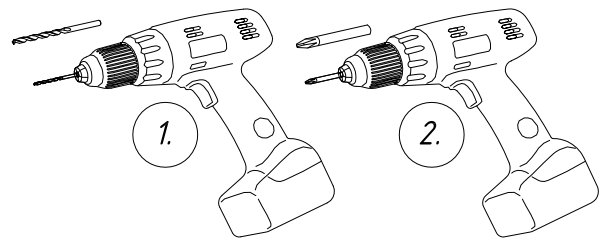

FaB3-1 4 pcs  
Dia-1 2 pcs  
3.5x40 24 pcs

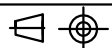
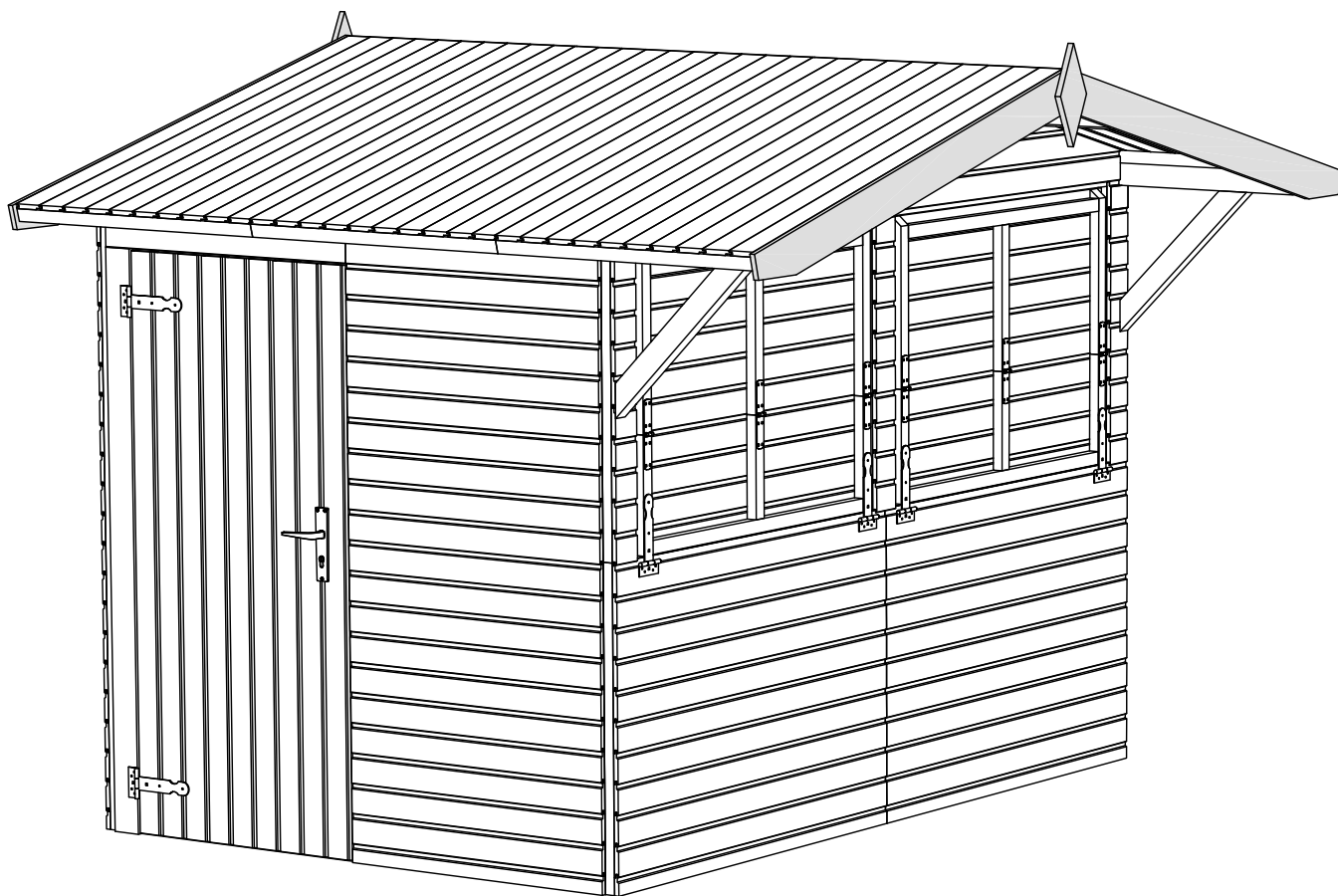
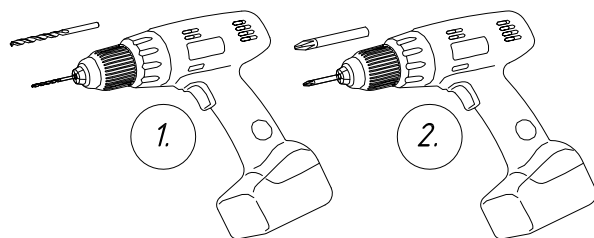



CnB4 1 pcs  
3x30 10 pcs

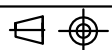
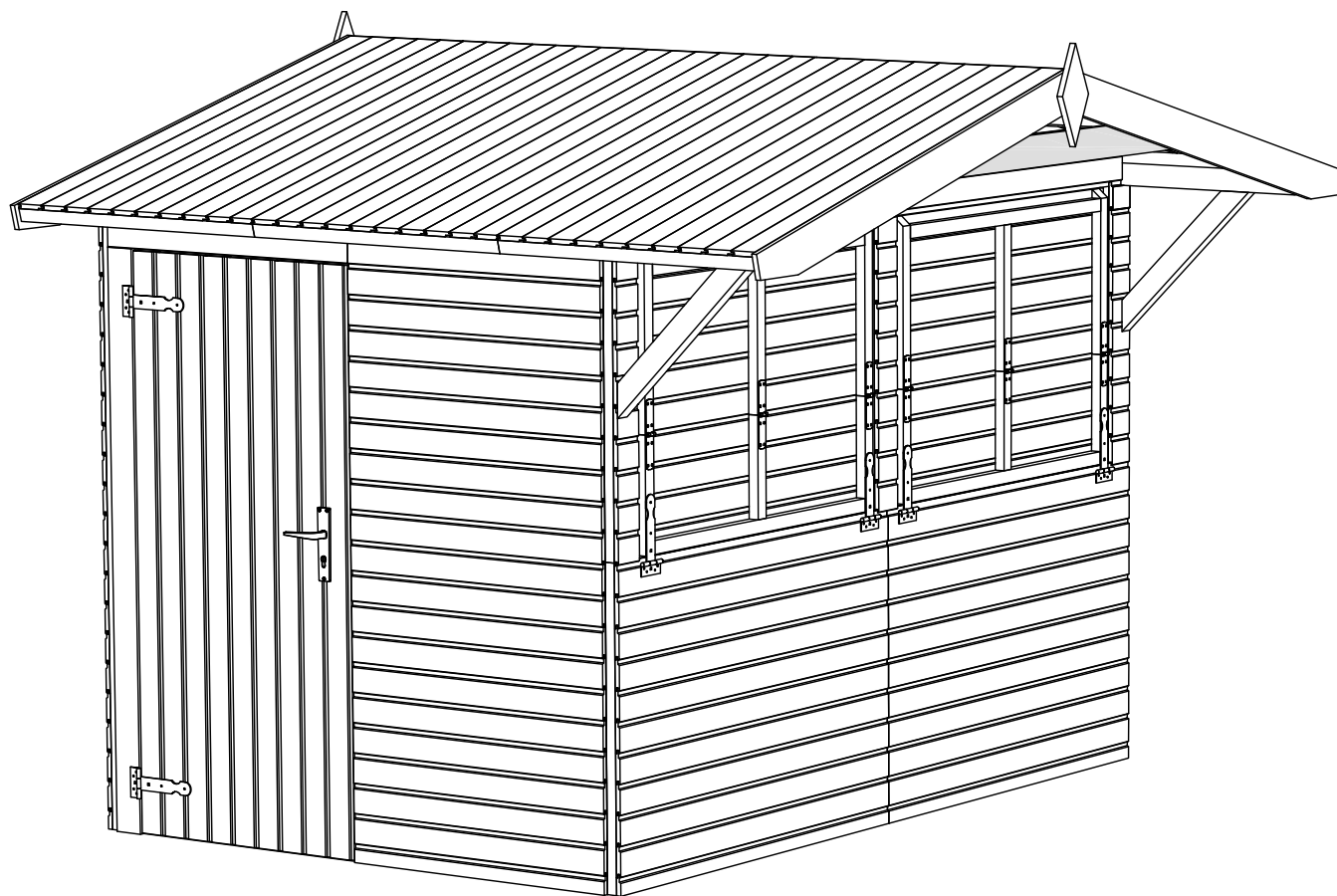
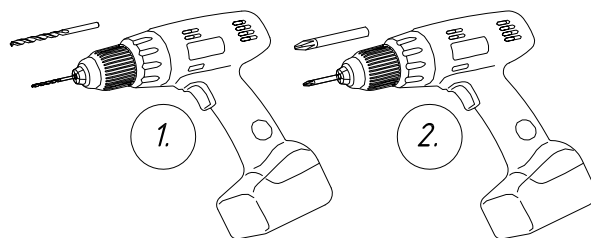

CoB1 1 pcs  
CoB2 8 pcs  
CoB4 1 pcs  
3,5x40 50 pcs

